

SALICRU

2006

- Presentación de producto



CE



Características generales

-Tecnología INTERACTIVO

-Onda senoidal

-Gama de Potencias de 1250VA (875W) y 2000VA (1500W)

- Fácil de usar y robusto con el entorno

-Pensado para que en situaciones críticas de falta de suministro eléctrico tengas:

- opción de programar el regulador
- opción de disponer de la información necesaria para poder tomar decisiones
- la certeza de no poner en riesgo la seguridad de las personas



SPS TRAFFIC LIGHT

Funcionamiento

Normal

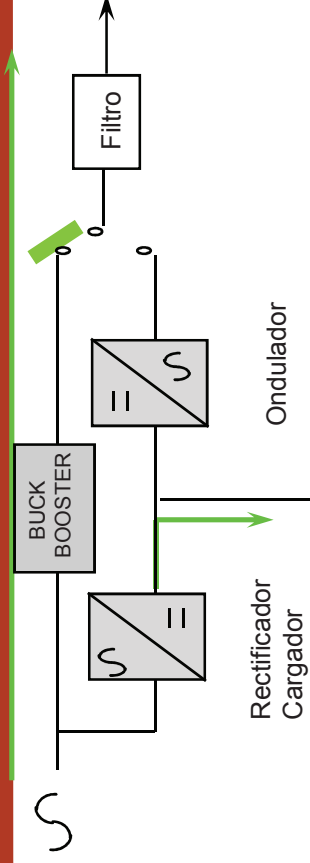

Fluctuaciones

de tensión

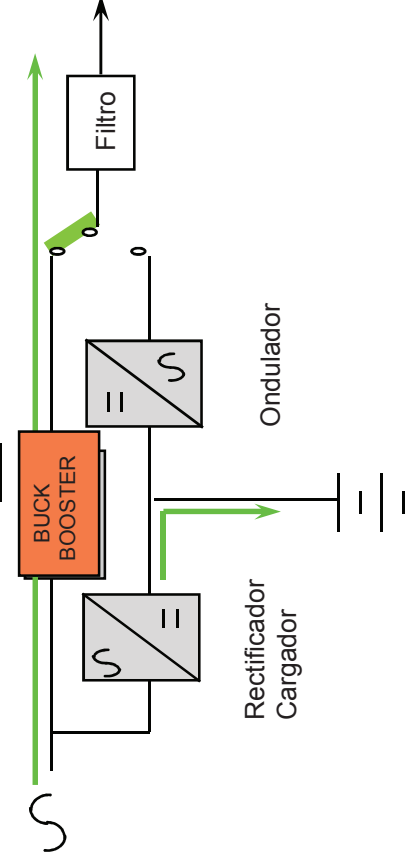

Ausencia

de Alimentación

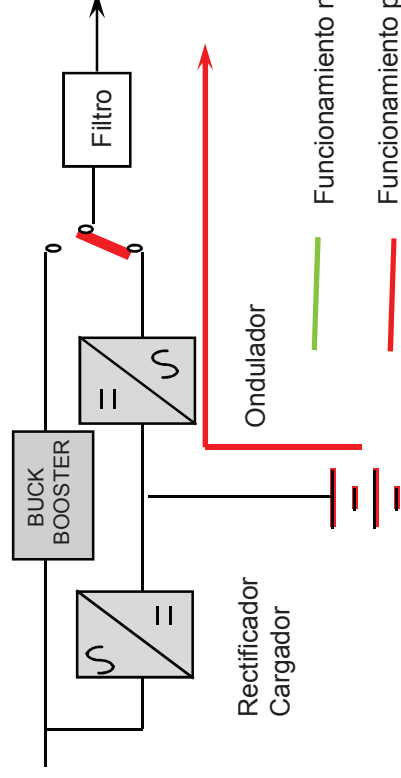

Funcionamiento normal

Funcionamiento por batería



Características:

- Autonomía extendida con un cargador de 6/10 A y posibilidad de llevar baterías externas
- 6 relés programables
- Acceso remoto vía puerto serie RS232
- Posibilidad de software de gestión (windows)
- Histórico de hasta 100 eventos y Alarmas
- Indicación del número de cortes y de su duración
- Selección de funcionamiento Normal / Flash Mode



SPS TRAFFIC LIGHT

Monitorización Local:

-DISPLAY AVANZADO



Display LCD retro iluminado

Teclado de programación para monitorizar, ver estado, o calibrar

Fácil de leer en cualquier condición de luz

Información en tiempo real:

Input / Output status

Porcentaje de batería disponible

Nivel de carga



SPS TRAFFIC LIGHT

Conectividad

- La integración de sistemas y las comunicaciones dependen de la conectividad que nos ofrezca un equipo.

Para ello el SPS TRAFIC LIGHT incorpora contactos libres de potencial NC/NA programables para aportar gran versatilidad al sistema de regulación de tráfico tanto en modo normal como en operaciones durante en modo de descarga

Ademas incluye un puerto serie RS232 para disponer de unas plenas comunicaciones remotas.

-Disponible como opcional encontramos un sistema de transferencia estático (PTS) que nos permite aislar completamente la unidad. Permitiendo trabajos de mantenimiento sin corte de suministro en la intersección

- Reporte de Estado y Eventos

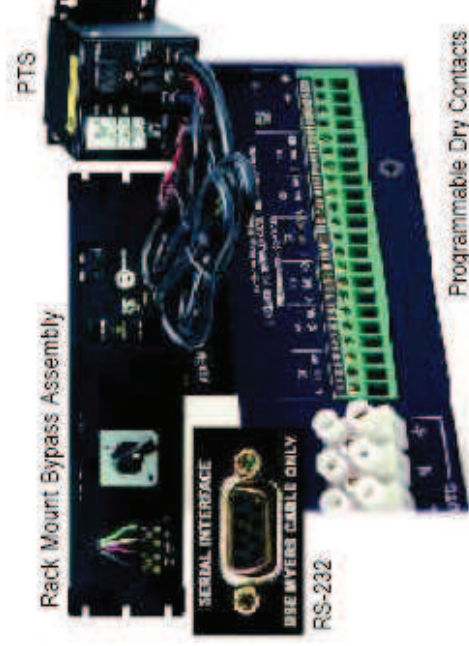



SPS TRAFFIC LIGHT

Principales Prestaciones

- Formato mecánico apto para cualquier tipo de armario regulador de tráfico
- Baja distorsión armónica AC de salida
- Ajuste del nivel de voltage AC: 208/220/230/240
- Protección contra picos transitorios (spikes) de la línea
- Conexiones externas por la parte frontal
- LED de indicación para funcionamiento:
 - En Línea
 - En batería
 - Batería baja
 - Sobrecarga
 - Fallo general
- Protección contra subtensiones (brownout) – activación automática del ‘boost’
- Carga de baterías por compensación de la Temperatura. Muy interesante para aplicaciones ‘outdoor’

Principales Prestaciones

- Supresión de ruidos, clase A
- Niveles de Operación:
 - Operación en Modo Normal: mantiene siempre todas las prestaciones
 - Operación en Modo Flash: para intersecciones que excedan los módulos especificados de salida
 - Operación en Modo Normal/Flash: proporciona una alimentación en Modo Normal hasta el 40% de la capacidad de la batería y entra en Modo Flash en el tramo final de autonomía.





SPS TRAFFIC LIGHT

Características Eléctricas

- Tensión entrada: 230VAC
- Frecuencia: 50 Hz
- Márgenes de entrada: -23% / + 17%
- Forma de onda: senoidal
- Rendimiento: 95-97 %
- THDv: < 3%
- Corriente max entrada: 12A (1250VA) / 20A (2000VA)
- Potencias: 1250VA (875W) / 2000VA (1500W)
- Corriente de carga baterías: 6A (1250VA) / 10A (2000VA)
- Tiempo de transferencia < 60ms
- Nivel de ruido < 32 dBA
- Temperatura de funcionamiento: -37°C / +74°C
- Dimensiones: 279x432x133 (19" , 3U)

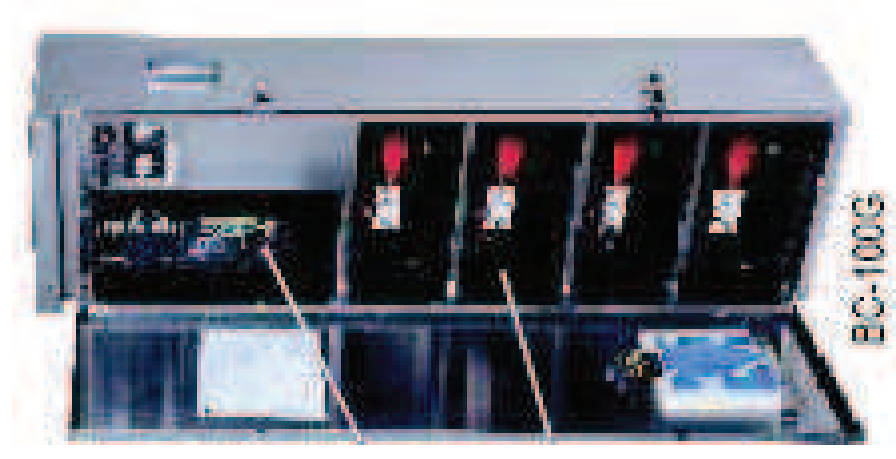



SPS TRAFFIC LIGHT

Posibles montajes

- montaje vertical o horizontal

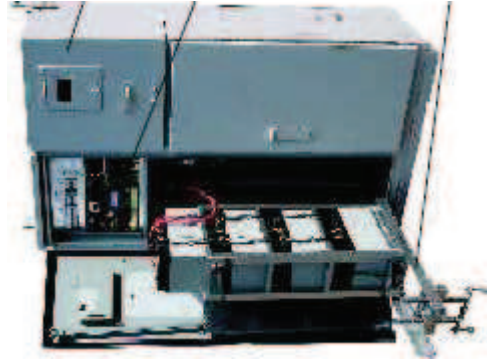

MENÚ DE COMUNICACIONES EN WINDOWS HYPER TERMINAL

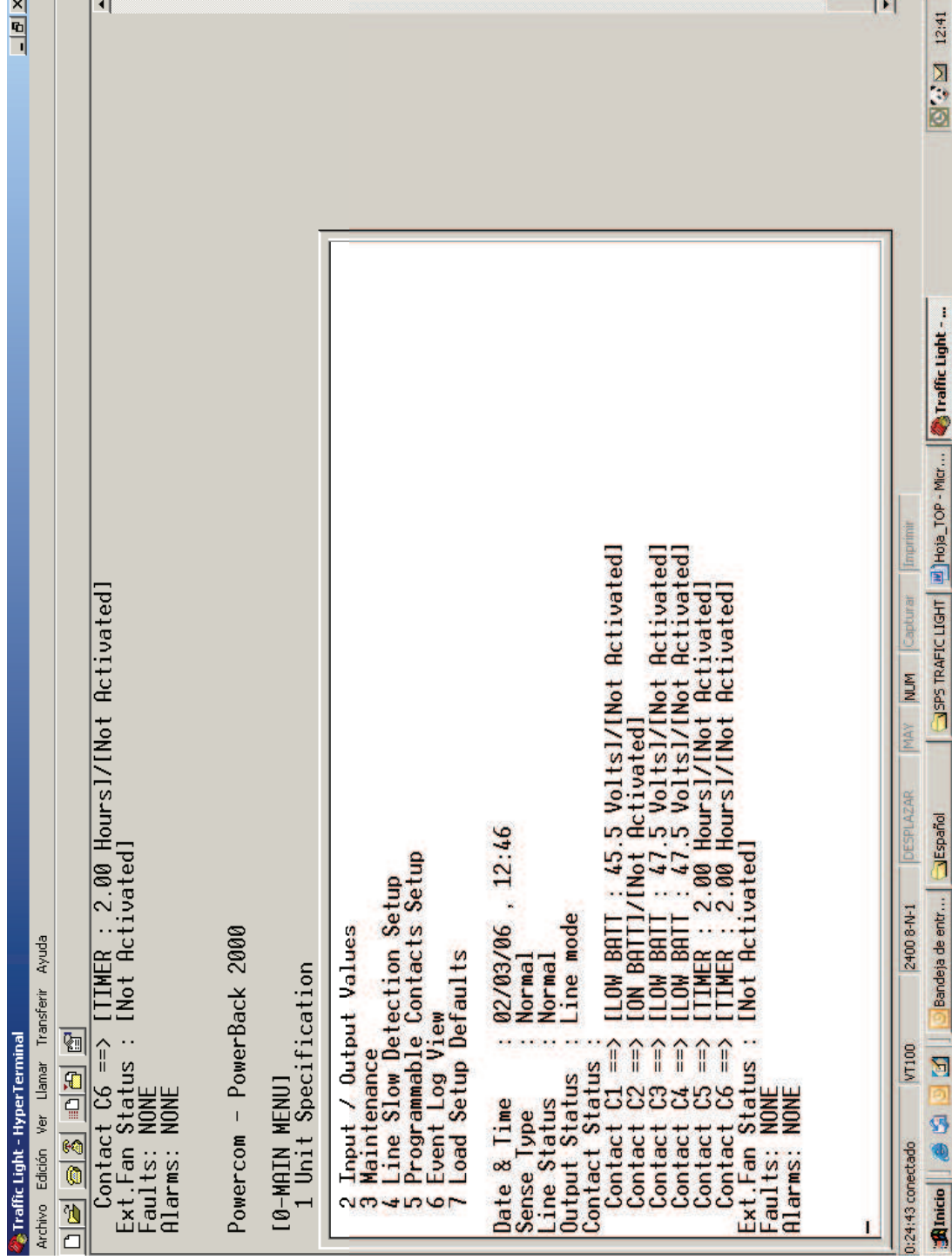

```

Traffic Light - HyperTerminal
Archivo Edición Ver Llamar Transferir Ayuda
Contact C6 ==> [TIMER : 2.00 Hours]/[Not Activated]
Ext.Fan Status : [Not Activated]
Faults: NONE
Alarms: NONE

Powercom - PowerBack 2000

[0-MAIN MENU]
1 Unit Specification

2 Input / Output Values
3 Maintenance
4 Line Slow Detection Setup
5 Programmable Contacts Setup
6 Event Log View
7 Load Setup Defaults

Date & Time      : 02/03/06 , 12:46
Sense Type      : Normal
Line Status     : Normal
Output Status   : Line mode
Contact Status  :
Contact C1 ==> [LOW BATT : 45.5 Volts]/[Not Activated]
Contact C2 ==> [ON BATT]/[Not Activated]
Contact C3 ==> [LOW BATT : 47.5 Volts]/[Not Activated]
Contact C4 ==> [LOW BATT : 47.5 Volts]/[Not Activated]
Contact C5 ==> [TIMER : 2.00 Hours]/[Not Activated]
Contact C6 ==> [TIMER : 2.00 Hours]/[Not Activated]
Ext.Fan Status  : [Not Activated]
Faults: NONE
Alarms: NONE

```

MENÚ DE COMUNICACIONES EN WINDOWS HYPER TERMINAL

```
Traffic Light - HyperTerminal
Archivo Edición Ver Llamar Transferir Ayuda

1
[0-MAIN MENU]
[1-UNIT SPECIFICATION]
POWERBACK
Unit Model
Unit Freq
Input Voltage
Output Voltage
Output VA
Battery Voltage

Max Char Current
EEPROM Version

2
[0-MAIN MENU]
[2-INPUT/OUTPUT VALUES]
Input:-
Voltage
Freq
Output:-
Voltage
Freq
Power
Battery:-
Temperature
Voltage
Evt/Timer
INV Event
INV Timer
```

0:29:09 conectado VT100 2400 8-N-1 DESPLAZAR MAY MUJ Capturar Imprimir Traffic Light - HyperTe... 12:45

MENÚ DE COMUNICACIONES EN WINDOWS HYPER TERMINAL

```

Traffic Light - HyperTerminal
Archivo Edición Ver Llamar Transferir Ayuda
[0]-MAIN MENU
[2]-INPUT/OUTPUT VALUES
  Input:-
    Voltage 226 Volts
    Freq 50.0 Hertz
  Output:-
    Voltage 225 Volts
    Freq 50.0 Hertz
    Power 0000 Watts
  Battery:-
    Temperature 21 Deg C
    Voltage 56.9 Volts
  Evt/Timer
    INV Event 00000
    INV Timer 0000 Hours 00 Minutes

3
[0]-MAIN MENU
[3]-MAINTENANCE]
30 Battery Test Options (available in Line Mode)
31 Output Shutdown
32 Inverter On/Off (available in Standby/Battery Mode)
33 Change Password (can only be changed in Line Mode)
34 Line Qualify Time
35 Battery Voltage Level % Capacity Remaining
36 Load Shed Timer On/Off (available in Battery Mode only)
37 Resets The Event/Timer Counters (available in Line Mode)
38 Battery Charging Temperature Compensation
39 Ext. Fan On/Off By Temperature
  
```

MENÚ DE COMUNICACIONES EN WINDOWS HYPER TERMINAL

```

Traffic Light - HyperTerminal
Archivo Edición Ver Llamar Transferir Ayuda
30 Battery Test Options (available in Line Mode)
31 Output Shutdown
32 Inverter On/Off (available in Standby/Battery Mode)
33 Change Password (can only be changed in Line Mode)
34 Line Qualify Time
35 Battery Voltage Level % Capacity Remaining
36 Load Shed Timer On/Off (available in Battery Mode only)
37 Resets The Event/Timer Counters (available in Line Mode)
38 Battery Charging Temperature Compensation
39 Ext. Fan On/Off By Temperature

4
[0-MAIN MENU]
[4-LINE SLOW DETECTION SETUP]
40) Slow Detect High Lmt [287] Vac
41) Slow Detect Low Lmt [177] Vac
42) Slow Detect High Hyst [281] Vac
43) Slow Detect Low Hyst [183] Vac
44) Slow Detect Boost High [213] Vac
45) Slow Detect Boost Low [207] Vac
46) Slow Detect Buck High [253] Vac
47) Slow Detect Buck Low [247] Vac

35
[0-MAIN MENU]
[3-MAINTENANCE]
[35-BATTERY VOLTAGE LEVEL % CAPACITY REMAINING]
Current voltage setting is [47.5 Volts]
Enter new value. (42..55)
>_
0:33:27 conectado WT100 2400 8-N-1 DESPLAZAR MAY NUM Capturar Imprimir
Inicio Captures menus hyperter... Traffic Light - HyperTe... Apartat 6 - Paint 12:50

```

MENÚ DE COMUNICACIONES EN WINDOWS HYPER TERMINAL

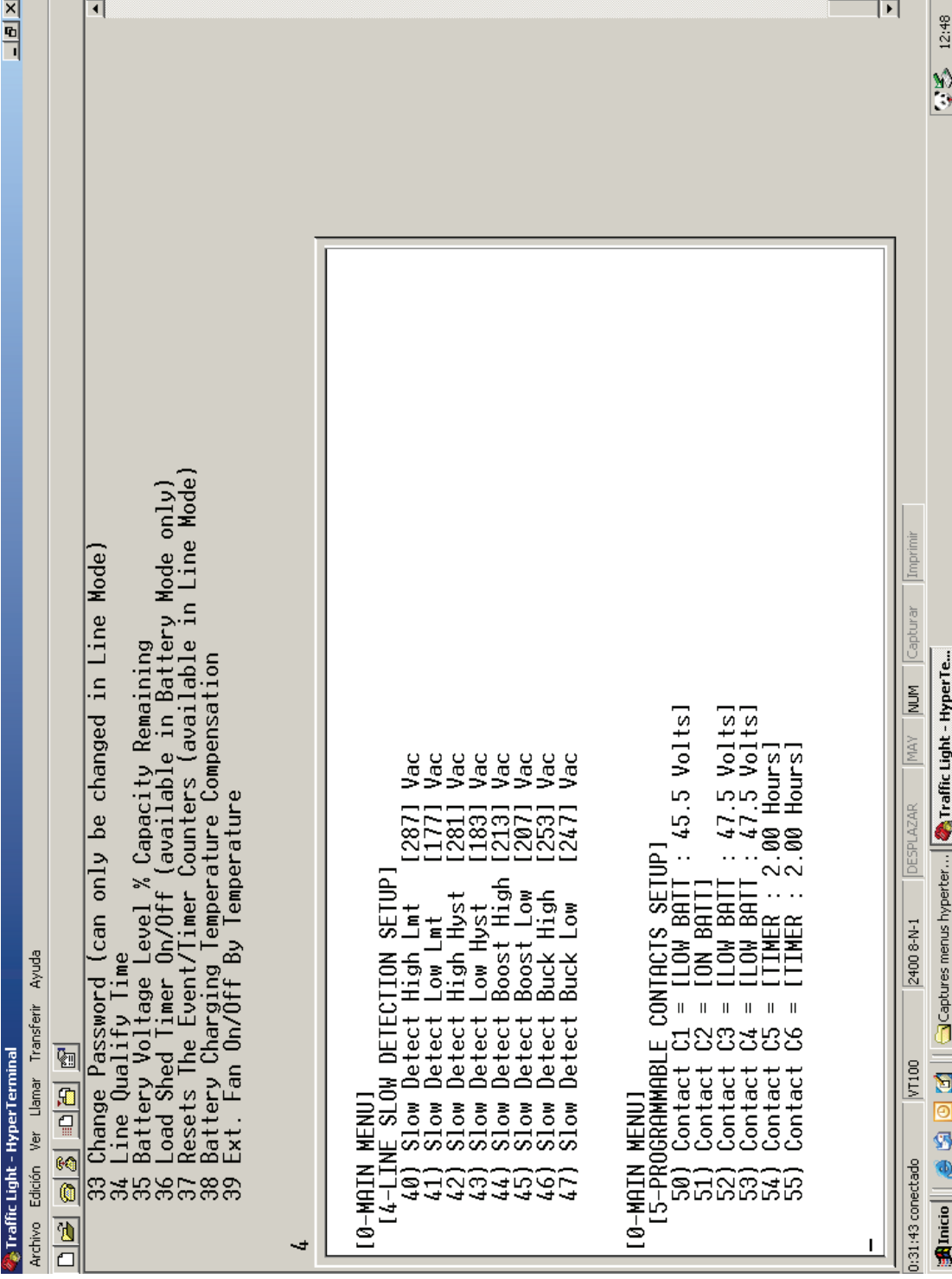

```

Traffic Light - HyperTerminal
Archivo Edición Ver Llamar Transferir Ayuda
[Icons]
33 Change Password (can only be changed in Line Mode)
34 Line Qualify Time
35 Battery Voltage Level % Capacity Remaining
36 Load Shed Timer On/Off (available in Battery Mode only)
37 Resets The Event/Timer Counters (available in Line Mode)
38 Battery Charging Temperature Compensation
39 Ext. Fan On/Off By Temperature

4
[0-MAIN MENU]
[4-LINE SLOW DETECTION SETUP]
40) Slow Detect High Lmt [287] Vac
41) Slow Detect Low Lmt [177] Vac
42) Slow Detect High Hyst [281] Vac
43) Slow Detect Low Hyst [183] Vac
44) Slow Detect Boost High [213] Vac
45) Slow Detect Boost Low [207] Vac
46) Slow Detect Buck High [253] Vac
47) Slow Detect Buck Low [247] Vac

[0-MAIN MENU]
[5-PROGRAMMABLE CONTACTS SETUP]
50) Contact C1 = [LOW BATT : 45.5 Volts]
51) Contact C2 = [ON BATT]
52) Contact C3 = [LOW BATT : 47.5 Volts]
53) Contact C4 = [LOW BATT : 47.5 Volts]
54) Contact C5 = [TIMER : 2.00 Hours]
55) Contact C6 = [TIMER : 2.00 Hours]

0:31:43 conectado VT100 2400 8-N-1 DESPLAZAR MAY NUM Capturar Imprimir
Inicio [Icons] Captures menus hyperterm... Traffic Light - HyperTe... 12:48
  
```

MENÚ DE COMUNICACIONES EN WINDOWS HYPER TERMINAL

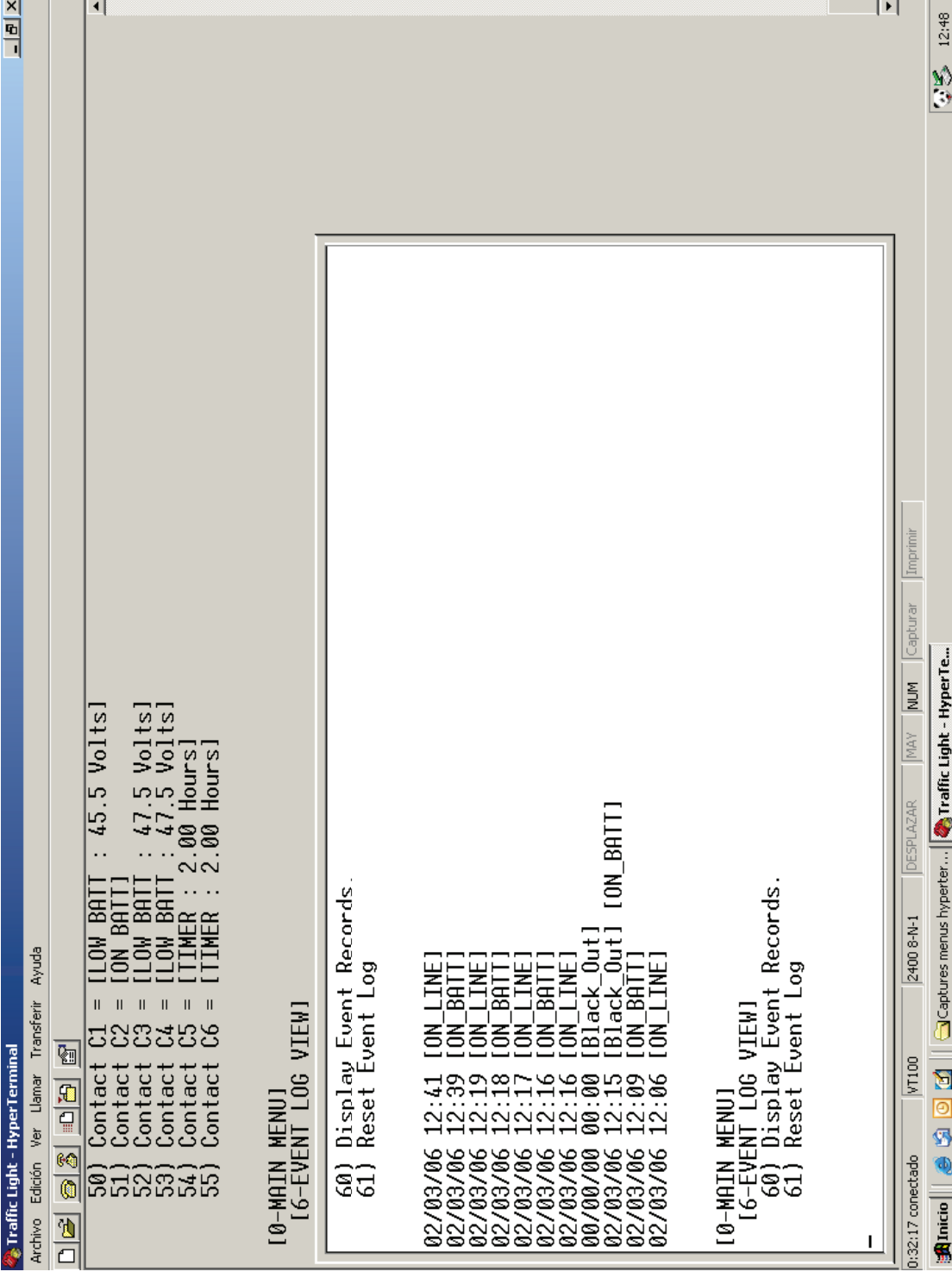

The screenshot shows a HyperTerminal window titled "Traffic Light - HyperTerminal". The window contains the following text:

```
Archivo Edición Ver Llamar Transferir Ayuda
```

```
50) Contact C1 = [LOW BAIT : 45.5 Volts]
51) Contact C2 = [ON BAIT]
52) Contact C3 = [LOW BAIT : 47.5 Volts]
53) Contact C4 = [LOW BAIT : 47.5 Volts]
54) Contact C5 = [TIMER : 2.00 Hours]
55) Contact C6 = [TIMER : 2.00 Hours]

[0-MAIN MENU]
[6-EVENT LOG VIEW]

60) Display Event Records.
61) Reset Event Log

02/03/06 12:41 [ON_LINE]
02/03/06 12:39 [ON_BATT]
02/03/06 12:19 [ON_LINE]
02/03/06 12:18 [ON_BATT]
02/03/06 12:17 [ON_LINE]
02/03/06 12:16 [ON_BATT]
02/03/06 12:16 [ON_LINE]
00/00/00 00:00 [Black Out]
02/03/06 12:15 [Black_Out] [ON_BATT]
02/03/06 12:09 [ON_BATT]
02/03/06 12:06 [ON_LINE]

[0-MAIN MENU]
[6-EVENT LOG VIEW]
60) Display Event Records.
61) Reset Event Log
```

The taskbar at the bottom shows the system clock as 0:32:17 conectado, the network icon, and the system tray with icons for Inicio, Internet Explorer, and other background applications. The system tray also includes a volume icon, a network icon, and a system clock showing 12:48.

SALICRU

FIN



PB-2000ITS-E

Operator's Manual

Part #: 99-546 Rev 1

*For use with PB-2000ITS-E units with a Date of Manufacture of 2008-07-01 or later.
Firmware version 2.0 / 2.0 (Control/LCD) or higher*

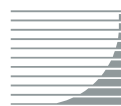

PEEK



IMPORTANT

EMERGENCY SHUTDOWN PROCEDURE ON THE INSIDE OF REAR COVER

For service, parts or technical information

contact:

US Traffic/Peek Traffic
Customer Service
2906 Corporate Way
Palmetto, FL USA 34221

1-800-245-7660

(941) 845-1200

FAX: (941) 845-1204

[Email: tech.support@peektraffic.com](mailto:tech.support@peektraffic.com)

SAVE THESE INSTRUCTIONS

TABLE OF CONTENTS

SAFETY INSTRUCTIONS	III
UNPACKING AND INSPECTION CHECKLIST	VI
■ Section 1: Installation & Start-Up Manual	1
1.1 DESCRIPTION	2
1.1.1 System Description	2
1.1.2 PowerBack 2000 UPS Controller	4
1.1.3 Power Transfer Switch	4
1.1.4 Batteries	5
1.2 MOUNTING	5
1.3 WIRING.....	6
1.4 START-UP AND TEST	9
1.5 SHUTDOWN	11
1.5.1 PowerBack 2000 UPS.....	11
1.5.2. PTS	12
1.6 TROUBLESHOOTING	13
1.7 SPECIFICATIONS	14
1.8 EMERGENCY SHUTDOWN PROCEDURE	15
■ Section 2: Operator's Manual	17
2.1 INTRODUCTION	19
2.1.1 The Advantages	20
2.1.2 A Tour of the PowerBack 2000	21
2.2 OPERATION	27
2.2.1 LCD Panel	28
2.2.2 PowerBack 2000 Operating Modes	29
2.2.3 Self Test	30
2.2.4 Start Up	31
2.2.4 Shutdown	32
2.2.6 Battery Replacement	33
2.2.7 LCD Menu Tree	34
2.2.8 Status Menu	35
2.2.9 Control Menu	36
2.2.10 Settings Menu	37
2.2.11 Maintenance Menu	39
2.2.12 Alarm Menu	40

2.2.13 Fault Menu	41
2.2.14 Event Log View	42
2.2.15 Low Battery Mode Status	43
2.2.16 Parameter Changes	43
2.3 COMMUNICATION	45
2.3.1 RS-232 Set-Up	46
2.3.1.1 RS-232 Connector at PowerBack.....	46
2.3.1.2 RS-232 Cable.....	46
2.3.1.3 Wiring Set-up Procedure	47
2.3.2 HyperTerminal Set-Up	48
2.3.3 Main Menu	52
2.3.4 Menu Tree & RS-232 Sub Menus	55
2.3.4.1 RS-232 Menu Tree	55
The complete MENU Tree with all default values.....	56
2.3.4.2 Unit Specifications, Input/Output Values	57
2.3.4.3 Input / Output Values.....	57
2.3.4.4 Maintenance	58
2.3.4.5 Line Slow Detection Parameters	60
2.3.5 Menu Tutorial	62
2.4 MAINTENANCE	65
2.4.1 Battery Back-Up Time Test	66
2.4.2 PowerBack Return Instructions	67
2.4.3 Troubleshooting	68
2.4.4 Contrast Adjustment for the LCD Display	69
2.4.5 Battery Maintenance	69
2.4.6 Specifications	70
WARRANTY	73
EMERGENCY SHUTDOWN PROCEDURE	74

IMPORTANT SAFETY INSTRUCTIONS ARE CONTAINED IN THIS MANUAL



To reduce the risk of electrical shock and to ensure the safe operation of the PowerBack 2000, the important safety instructions are marked with the symbols as shown below. These symbols are used throughout this manual and wherever they appear, it indicates that the instructions should be carried out only by qualified personnel.

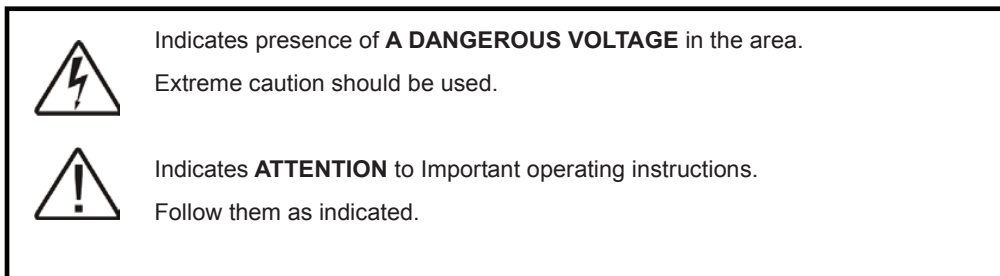

DANGER: Do not expose the PowerBack 2000 to rain or moisture.



DANGER: Total Earth ground leakage current of loads connected to the PowerBack 2000 should not exceed 2.4 mA.



The PowerBack 2000 generates, uses and can radiate radio frequencies if not installed and tested in accordance with the instructions contained in this manual. It has been tested and found to comply with the limits established for a Class A computing device pursuant to part 15 of FCC rules when it is operated alone. It also complies with the radio interference regulations of DOC, which are designed to provide a reasonable protection against such interference, when this type of equipment is used in a commercial environment. If there is interference to radio or TV reception, which is determined by switching it on and off, relocate the equipment or use an electrical circuit other than the one used by the PowerBack 2000.

IMPORTANT SAFETY PRECAUTIONS

Only qualified personnel should service or supervise the PowerBack 2000.



Danger: Sealed lead-acid batteries with high energy and chemical hazards are used. This manual contains important operation and safety instructions.

PowerBack 2000 Safety System Checklist

- Carefully unpack the PowerBack 2000. Report any shipping damage **at once**.
- **Read this manual.** If you have any questions about safe installation, operations or maintenance of the system, contact Customer Service.
- **Before installation,** confirm that the voltage and current requirements of the load(s) are compatible with the system's output. Confirm that the line voltage and current is compatible with the system's input requirements.
- The system should be installed on a dedicated power circuit.
- Place a warning label on the enclosure indicating that an Uninterruptible Power Supply (UPS) is located inside, in case of an Emergency.
- Use proper lifting techniques when moving system.
- The PowerBack 2000 has more than one live circuit. It is fed from AC as well as Battery power. Power may be present at the output(s) even if the system is disconnected from line power.
- When installing a PowerBack 2000 in a cabinet not provided with the system by the manufacturer, ensure that the environment meets the system specifications shown in Section 1.7, "Specifications" of this Manual.

SAVE THIS MANUAL

It contains important installation and operating instructions.

Keep it in a safe place

Battery Safety Checklist



- High & **dangerous voltages** are present inside the system. Only qualified personnel should perform installation and maintenance.
- Live battery wires **must not** touch the PowerBack 2000 chassis or any other metal objects. **This can cause a fire or explosion.**
- **Inspect** the batteries once a year for signs of cracks, leaks, or swelling. Replace as needed.
- When batteries are in storage, **charge** them at least once every three months for optimum performance and to extend their lifetime.
- **Always** replace batteries with the ones of identical type and rating. **Never** install old or untested batteries. **Never** mix old with new batteries. **Never** mix the different type of Battery within one system.
- Use **insulated tools** during servicing.
- **Remove** all rings, watches, jewelry, or other conductive items before working inside the enclosure.
- **Follow** local regulations for the disposal of batteries. Recycling is the best method.
- **Never** burn batteries to dispose of them. **They may explode.**
- Do not open the batteries. **The contents are toxic**

Stand-By Generator



Note: If the PowerBack 2000 constantly switches between Battery and Line modes because of line fluctuations, the input parameters should be **broadened from Normal to Generator** (see Section 2.2.10 "Sense Type")

In Generator mode, the acceptable range of input frequency and voltage is expanded to accommodate the voltage and frequency fluctuations created by a generator or a power source of such kind.

Use a generator with electronic speed and voltage controls which typically produces the Total Harmonic Distortion in % (THD) to be less than 10%. Generators with Mechanical governors can force the system to run continuously in Battery mode.

Before installation, compare the generator's output voltage to the PowerBack 2000's input voltage requirements as listed on both nameplates. To insure the system's smooth running, use a generator capable of supplying 2X or twice as much power as required by the total load.

Unpacking and Inspection Checklist

Purpose: Describes the unpacking and inspection procedures.

Carefully remove the PowerBack 2000 from its box. Inspect the contents and make sure the following items are included:

- One PowerBack 2000 UPS controller.
- One plastic bag containing following:
 - One temperature sensor cable with 3-pin connector.
 - Two sets of this Manual.
 - One Warranty Card.

The Power Transfer Switch (PTS) and all the associated wiring & hardware required for installation is supplied in a separate box.

The set of four (4) batteries that may be shipped separately, if a larger quantities of PowerBacks are supplied.



Tip: If any items are missing or damaged, contact the manufacturer and the shipping company at once. Most shippers have a short claim period.

SAVE THE ORIGINAL SHIPPING BOX

When returning the PowerBack 2000 for servicing, use the original shipping box with the supplied Styrofoam protectors. Manufacturer is not responsible for damage caused by improper packaging of returned systems.

READ THE OPERATOR'S MANUAL

Before installation, become familiar with the PowerBack 2000 by reviewing the procedures and drawings in this manual. If you have any questions about safe installation, operation, or maintenance, contact Customer Service.

Complete the following for records & future servicing

Model No. _____

Serial No. _____

Date of Manufacture _____

(Above items can be found on the nameplate label attached to the side of the unit)

Manufacturer Sales Order No. _____

Manufacturer P/N: _____

Your Purchase Order No. _____

Purchased from _____

(Following details are for installation location)

Installation Date. _____

Installed by _____

City _____

State/Province _____

Zip/Postal Code _____

Country _____

Telephone # _____

Fax # _____

E-Mail _____

Street names of Location _____

Cabinet / Controller type _____

THIS PAGE INTENTIONALLY LEFT BLANK

PowerBack 2000 ITS-E System Uninterruptible Power Supply Controller

- Section 1: Installation & Start-Up Manual

The traffic signal cabinet is powered continuously when above PowerBack 2000 system is installed. Above system allows connection for the normal utility power using standard terminal blocks or an optional Generator power via standard 30 Amp. Generator Plug. The optional Bypass switch allows above system to operate without the PTS or an UPS that may be removed for service or permanently.

The PTS allows normal utility to flow out to the traffic cabinet, when the utility line is qualified or is within the acceptable range as programmed. The UPS input is protected with one circuit breaker located at PTS as well as another located on the UPS module. When the UPS internal BOOST or BUCK is enabled, the PTS is activated normally allowing UPS to continuously boost the output when input is lower, buck or lower the output when input is higher or run from Batteries when input power is outside the specified acceptable range. The PTS has dual NEMA power receptacles for optional Battery heating pads or connecting a vacuum cleaner or a PC for the maintenance.

The Batteries are continuously maintained charged from a smart temperature compensated internal charger. For the protection of the Battery the charging of the battery is stopped when the outside temperature exceeds 50 degrees C. When the Batteries are fully charged, the smart charger provides continuously pulsating On-OFF trickle charge to keep the batteries topped-off or fully charged. When input power is not qualified or is outside the acceptable range, the UPS derives the DC power from the storage tank of four Batteries connected in series and maintains output power, till the batteries are depleted down to a safer level. The traffic intersection runs full phase AND / OR in flash mode as programmed by user. The user programmable contacts allows user to put the intersection in flashing immediately as soon as the input power is lost or after batteries are depleted down to a certain capacity that is determined and programmed by the user. The amount of back-up time battery power can provide depends on the Amp-hour capacity of the Batteries used.

1.1.2 PowerBack 2000 UPS Controller

The PowerBack 2000 UPS Controller shown below provides control functions and backup power as described above. For more information, please see section 2 of this Manual.

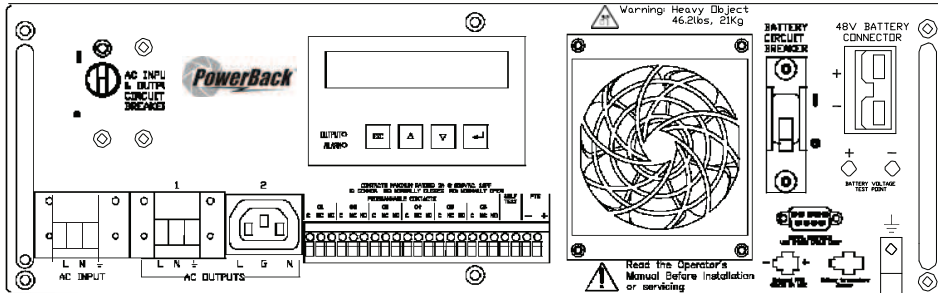

Figure 2

PowerBack 2000 UPS Controller Front Panel

1.1.3 Power Transfer Switch

The Power Transfer Switch (PTS) shown below allows the UPS to be removed for service, replacement or maintenance without interrupting power to the traffic cabinet.

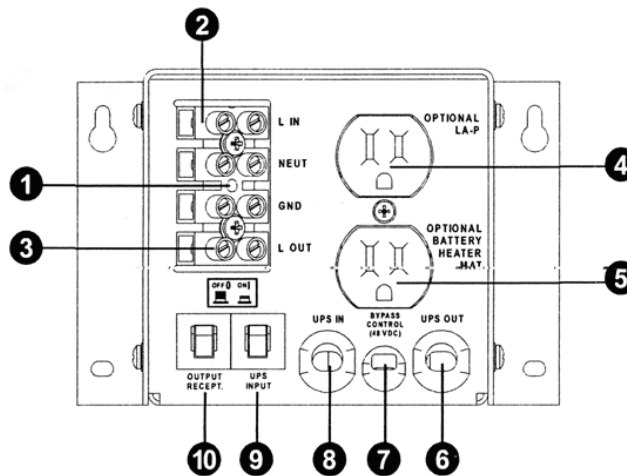

Figure 3

Power Transfer Switch Front Panel

1. The wires from the neutral and ground bus of the traffic cabinet are connected to this terminal block.
2. The Input line power is connected to the terminal block marked with "L IN".
3. The Output power is connected to the terminal block marked with "L OUT".

4. An optional surge suppressor, external PC or a vacuum cleaner for maintenance may be plugged into this receptacle.
5. The optional battery heater mat is plugged into this receptacle.
6. This "UPS OUT" cord is connected to one of the two OUTPUT AC terminal Blocks at PowerBack 2000.
7. The Red and Black PTS control wires are connected at terminals 21 & 22 of the green terminal block at the PowerBack 2000.
8. This "UPS IN" cord is connected to INPUT AC terminal Blocks at PowerBack 2000.
9. This circuit breaker provides input power protection for the PowerBack 2000 UPS.
10. The dual receptacles are protected by this circuit breaker.

1.1.4 Batteries

Different Amp-hour capacities or sizes of batteries can be used in the PowerBack 2000 system to provide various backup times. Four batteries are connected in series for the required 48VDC. Contact customer service for information on the battery best suited for your application. The battery harness supplied with the system is polarized and equipped with Anderson type connectors. Each battery can be unplugged from the system for the hot swap as the battery harness provides heavy-duty connector for each battery. Each of the four batteries may be connected in any random order using the provided harness.

1.2 Mounting

***Purpose:** Describes how to mount the PowerBack 2000 System into an enclosure.*

The PowerBack system components can be mounted into a single external cabinet or into the existing Traffic cabinet.

EXTERNAL MOUNT:

The factory supplied external cabinet can be bolted onto the existing or new traffic cabinet or this external cabinet can be pad mounted on a concrete slab or be pole mounted. The separate base for the cabinet for installation in the concrete slab, bolts & hardware for bolting onto the side of the traffic cabinet, bushing for the wire ducts, brackets for pole mounting and all the required accessories including mechanical hardware and electrical wiring are supplied to make the installation easy for the contractor. External cabinets such as BC100, BC80, etc. are outdoor type, weather proofed provided with internal exhaust fan that is temperature controlled, an intake filter that can be cleaned or replaced, a non-corrosive rubber mat for batteries, 3 point lock mechanism, lockable handle with dual keys and a unique internal keyed lock. The quality of cabinets bears a reputable industry trade name such as GIBBONS ENCLOSURES. The factory-supplied cabinet meets or exceeds the requirements of various NEMA classifications.

INTERNAL MOUNT:

The PowerBack components can also be mounted inside an existing NEMA or 332 or various other traffic cabinets. The special Swing Tray designed to hold the four batteries are easily mounted inside an existing 332 type other equivalent cabinets using the hardware that is provided or they can be shelf mounted in an NEMA or equivalent cabinets. The PowerBack can be bolted into an industry standard 19" rack using the supplied Ears or brackets, OR it can be shelf mounted in an NEMA type enclosures. The PTS supplied with or without optional Generator & Bypass switch comes in many configuration that can be shelf mount, 19" rack mount, back plate mount, etc...

1.3 Wiring

Purpose: Describes how to wire the PowerBack 2000 System.



Danger: The utility input power line **must** have circuit breaker or fuse protection as per the local electrical code. It is referred as “Upstream Circuit Breaker” in this manual.

Before wiring the system, determine the size of the load:

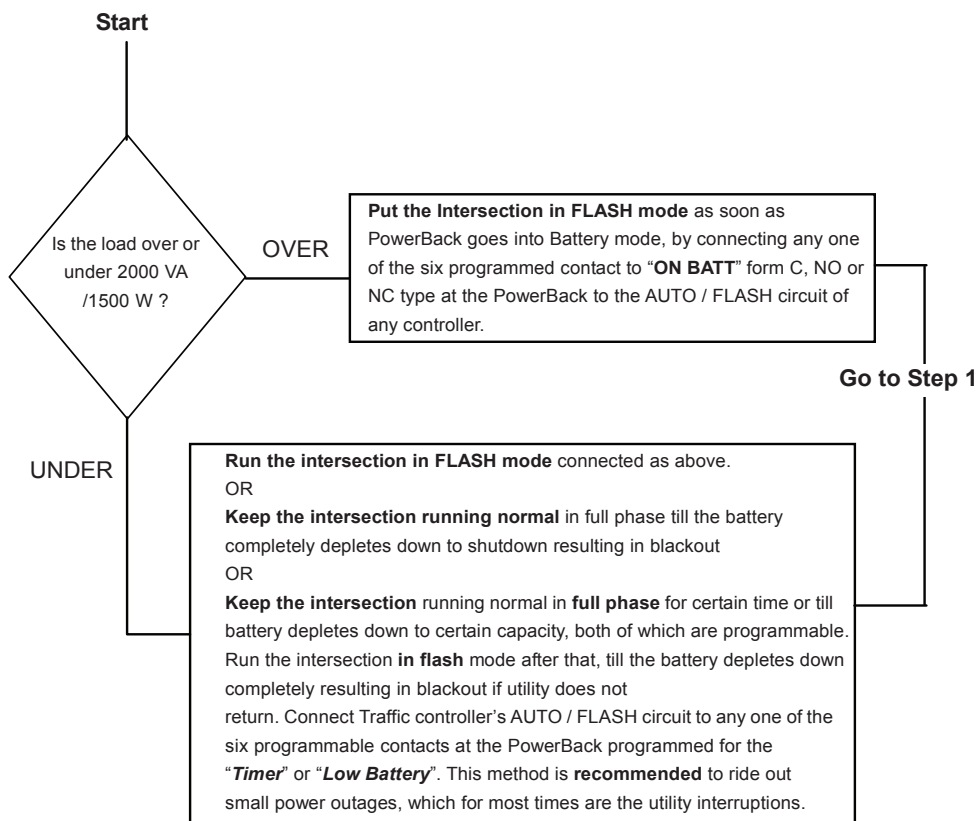

TIP: Each of the six contacts are of form C type, meaning Normally Open (NO), common (C) and Normally Closed (NC) dry contact rated for 1 Amp at 240 VAC. Each of these contacts can be individually programmed to energize and stay latched for ON BATTERY, LOW BATTERY, TIMER, ALARM, FAULT and many other conditions as described in subsequent chapters. The ON BATTERY contact/(s) are activated as soon as the PowerBack is transferred to Battery mode. LOW BATTERY contact/(s) are activated only in the battery mode, as soon as the discharged battery reaches the lower value battery capacity as set by user and remains latched as long as the system remains in Battery mode. The TIMER contact/(s) are activated only in the Battery mode after the user-programmed time is attained, that can be set in 15 minutes interval from 15 minutes to 8 hours.

TIP: Verify that all Breakers, AC and Battery Breakers are OFF prior to start of wiring.

Step 1: Connect CONTROL wires.

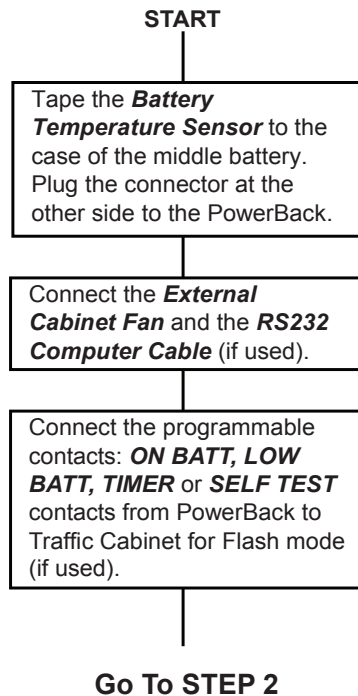

Wrap a tie around the strain relief loop and the battery temperature sensor to prevent the disconnecting during an earthquake or other severe vibrations.



TIP: Torque status/self test terminal block to a maximum of 4.4 lb-in (0.5 Mm). Maximum wire size is 14 AWG.

TIP: See section 2.1.2, fig. 6 of this Manual for details on Terminal Block.

Step 2: Connect PTS to the PowerBack.

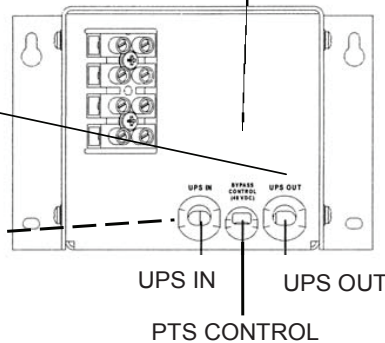
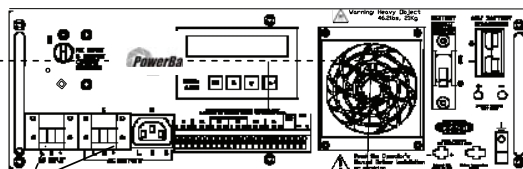
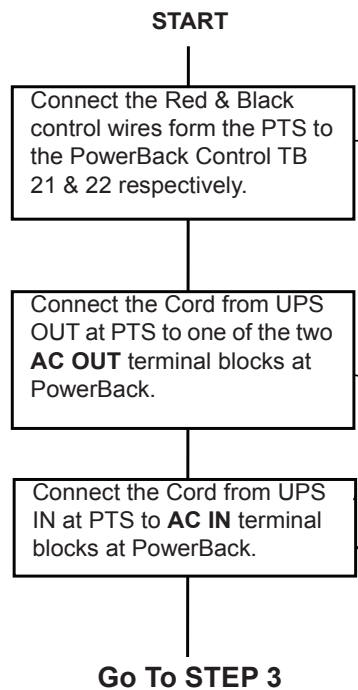

Step 3: Connect the output of Signal Cabinet and Battery.

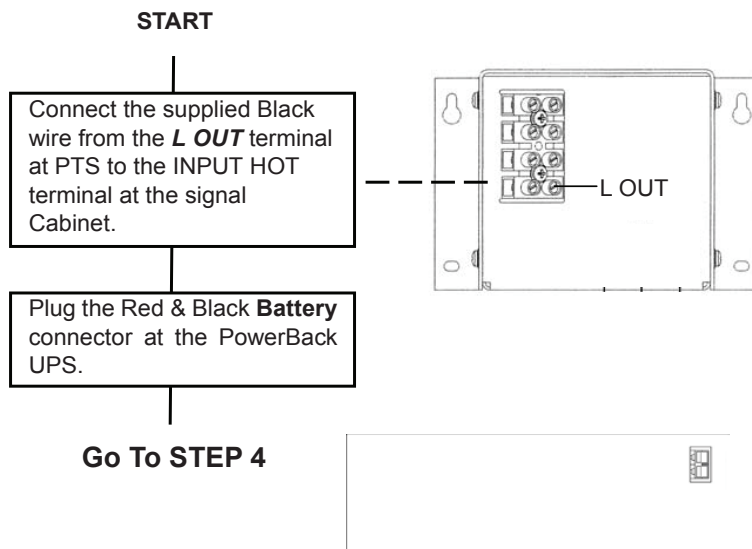

TIPS:

1. The wires from Ground and Neutral Bus Bars from the traffic cabinet are extended to PTS Terminal Block as shown in step 4.
2. OPEN the upstream breaker feeding utility Power to the signal Cabinet.
3. Cut the HOT wire (Black) connected between Utility and Traffic Cabinet.
4. The Cabinet side HOT wire is connected to "L OUT" at the PTS.
5. The Utility side HOT wire is connected to "L IN" at the PTS.
6. Torque the PTS terminal block to a maximum of 10.0 lb-in (1.1 Mm).

Step 4: Connect the Utility Input Line Power.



DANGER: Make sure the upstream circuit breaker feeding the Utility Power is **OFF** before beginning this step. Leave the NEUTRAL and GROUND wires connected from Utility to Signal Cabinet. Extend the NEUTRAL and GROUND wires from their corresponding Bus Bars in Traffic Cabinet to the Terminal block at PTS.

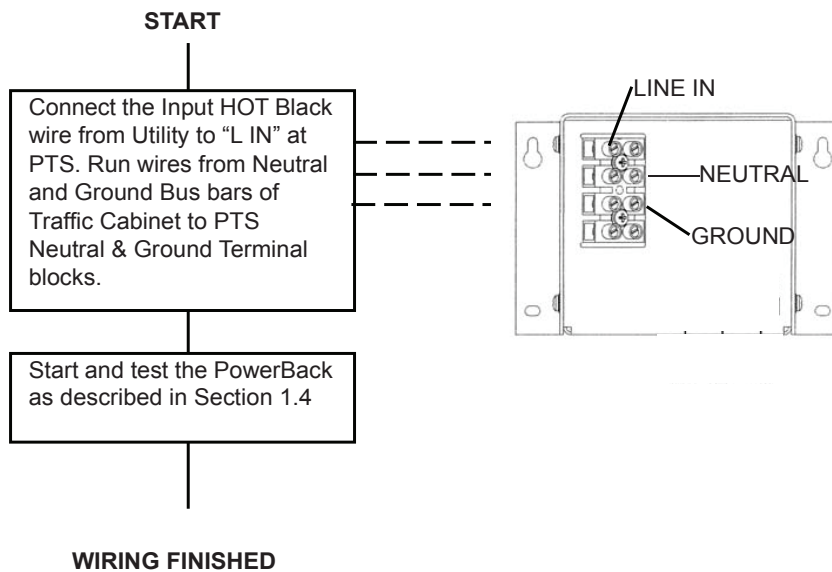

1.4 Start-up and Test

Purpose: Describes how to Start-up and test the system.

TIP: If the system does not perform as described below, see the troubleshooting section in Section 1.6 of this manual.

Step 1: Turn on the Utility Input line Power

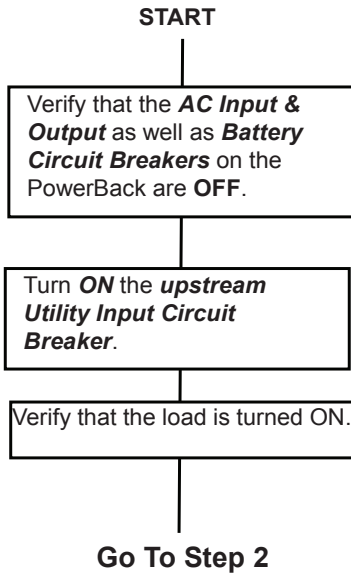

Step 2: Turn on the UPS.

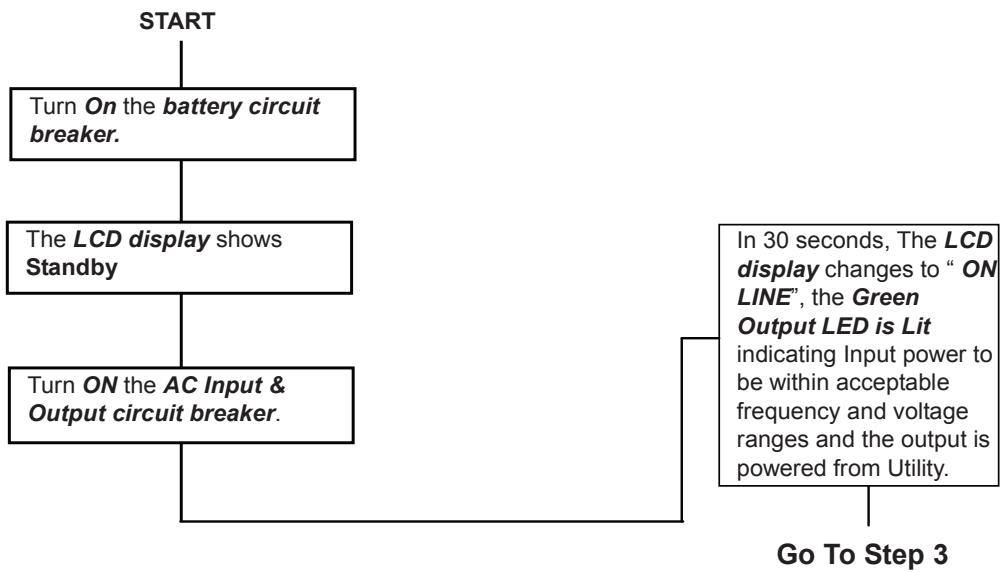

Step 3: Test the system.

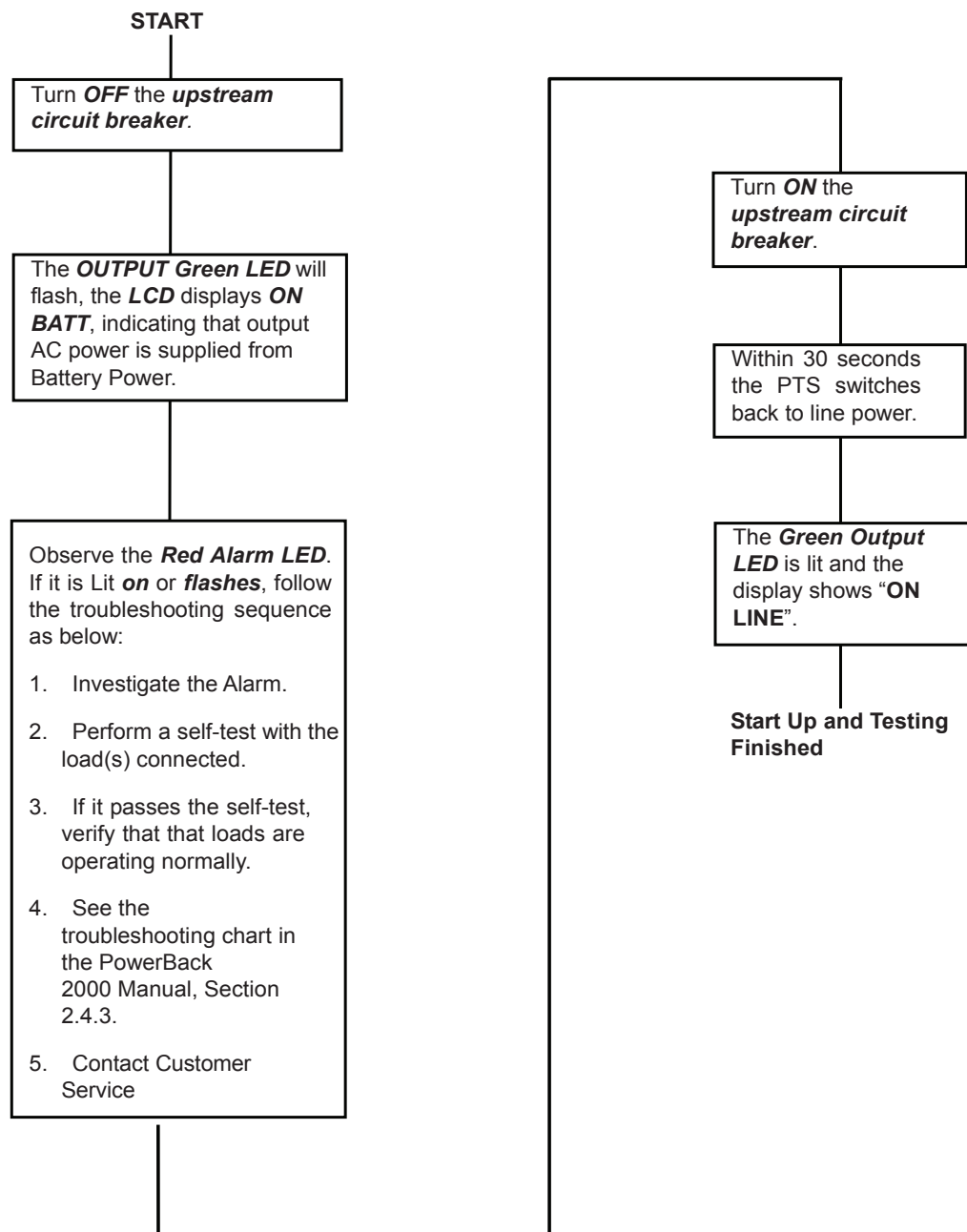

TIP: To test the UPS, perform the self-test feature via the control submenu (see this Manual, section 2.2.3, “Self Test”).

1.5 Shutdown

Purpose: Describes how to shut down the system components for removal or maintenance.

1.5.1 PowerBack 2000 UPS



Danger: Shutting down the PowerBack **does not** necessarily disconnect power to the loads.

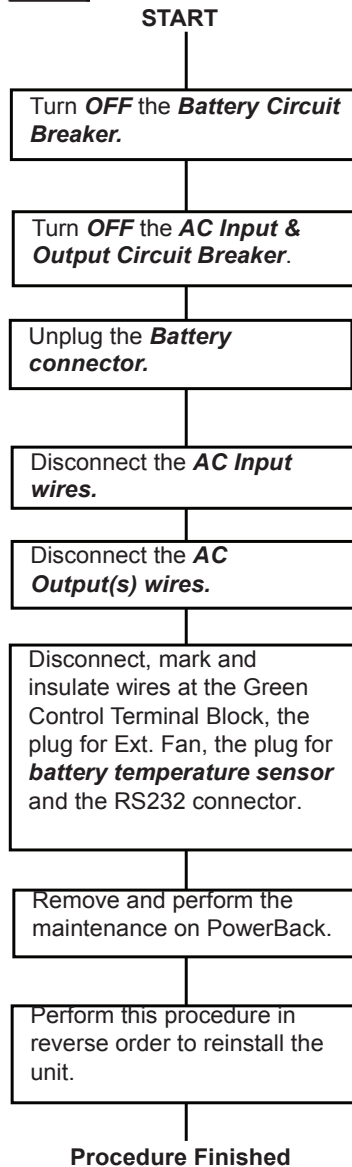

Danger: The AC input wires from PTS are still HOT or Live. Insulate the bare wires using wire nuts.

TIP: For additional information on how to operate the PowerBack 2000, see Section 2.2, Manual.

1.5.2 PTS

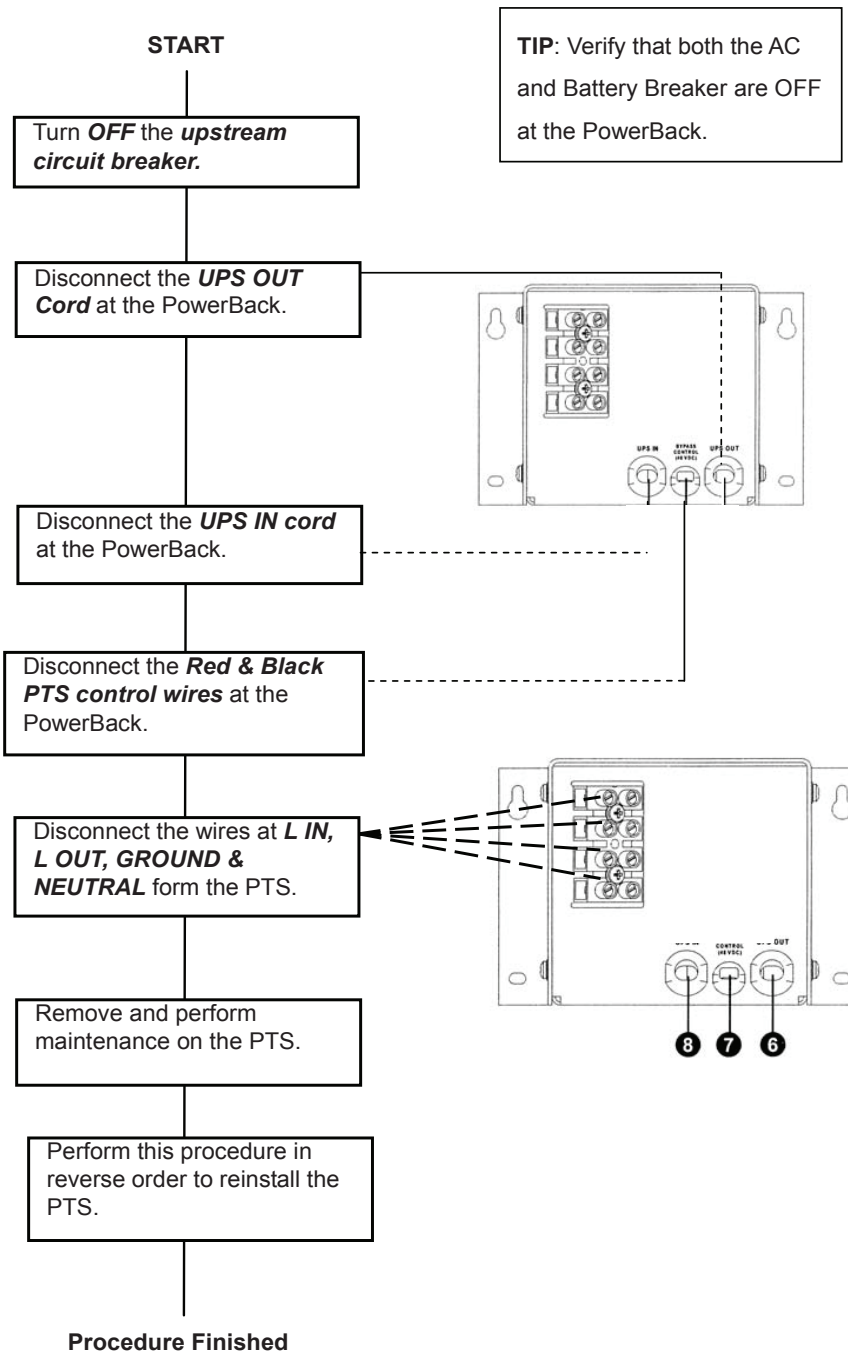

1.6 Troubleshooting

TIP: For troubleshooting the PowerBack 2000 UPS Controller, see Sections 2.2.3 and 2.4.3 of this manual.

PowerBack 2000 System Troubleshooting Chart		
SYMPTOM	CAUSE	REMEDY
No Output available from PTS	Upstream Utility circuit breaker or Fuse may be OPEN.	CLOSE the Upstream Utility Breaker or Fuse.
	Utility AC Power not Available.	Check with the AC Voltmeter & contact the Utility company.
	Wiring error at PTS Terminal Block.	Correct wiring at PTS.
	Faulty PTS.	If 120 VAC is present at “L IN” and NEUTRAL at the PTS Terminal Block, replace the PTS.
PTS won’t allow transfer to Battery mode.	PowerBack 2000 output power not connected to PTS.	Verify that “UPS OUT” cord from PTS is properly connected to the AC OUTPUT Terminal Block at the PowerBack.
	“UPS INPUT” circuit breaker at PTS is open.	Reset the Breaker & clear the fault.
	Red and Black control wires from PTS are not connected at the Green Control Terminal Block TB21 & 22, at the PowerBack.	Check the connection at the PowerBack.
	48 VDC signal missing at TB 21 and 22 of Green Control Terminal Block at the PowerBack.	Refer to Section 2.4.3 of this Manual for further troubleshooting.
	Faulty PTS.	Replace PTS.
PowerBack 2000 does not Return back to Input Line Mode.	Utility Input Line Power is Missing.	Verify that “UPS IN” cord from PTS is properly connected to the AC INPUT Terminal Block at the PowerBack.
		Verify that the “UPS INPUT” circuit breaker at PTS is closed.
		Ensure that the Utility Input is present.

1.7 Specifications

System Technical Specifications

INPUT

Voltage Range, VAC	199~262VAC(220/230/240 VAC Nominal) Prog. 90~150VAC
Frequency	50 +/- 3 Hz
Current	15A (Resistive)
Step Load Response (50% Load Change)	1/2 Cycle Full Recovery (Full resistive load)
Short Circuit Protection	15 A Circuit Breaker
Battery String Voltage	48 VDC (Four 12VDC Battery)

OUTPUT

Power, VA / W (Line or Inverter mode)	2000 VA / 1500 W
Power Factor	0.75
Output Voltage, VAC Line and Buck/Boost Mode	Max. 220/230/240 VAC +/- 5% (follows the Input voltage)
Inverter Mode	220/230/240 VAC +/- 5%
Output Waveform	Sine Wave
Output Waveform THD	< 3% (Resistive Load)
Load Crest Factor	3:1 (Max)
Overload Capacity	110% for 3 min.

PERFORMANCE

PTS Transfer Time	< 65 ms
-------------------	---------

ENVIRONMENTAL

Operating Temp (See Notes below)	-37 to + 74°C.
Storage Temp	-50 to +75°C.
Humidity (Non-Condensing)	< 95%
Altitude (Note 2)	10,000ft /3000 m

PTS MECHANICAL

Dimensions (WxDxH) inch/mm	4.75/ 120.6(W) 6.5/165(D) 4.6/116.8 (H)
Weight (lb/kg)	7.0/3.2
Mounting	Wall Mount EARS, 4 points. Optional 19" rack mount.
Input Connection	Terminal Block
Output Connection To Loads	Terminal Block.
Output Connection To UPS	6 foot line cords ready for hard wiring to UPS terminal blocks
Cooling	Convection (Approx 7 W contactor coil dissipation)

CERTIFICATION AND APPROVALS

Electrical Safety	UL -1778, CSA-107.1, UL 1950
EMI	FCC Class A
Surge Immunity	Tested to: IEC 1000-4-5, IEEE C62.41

Note:

1. Between 55 ~ 74°C, the system is de-rated to a maximum rectified-capacitive load of 1500 VA /1200 W.
2. De-rate operating temperature above 4900 ft (1500m) by 2°C per 1000 ft (300m).
3. Refer to section 2.4.5 at the end of this Manual for additional Specifications.

Due to ongoing product improvements, specifications are subject to change without notice.

1.8 EMERGENCY SHUTDOWN PROCEDURE

The PowerBack 2000 UPS is connected to more than one energy source. In an emergency, DISCONNECT Utility Input Power, Battery Power, as well as an Optional Generator Power, if utilized. Disconnecting all the AC and DC power source will ensure that the output circuit is not live.

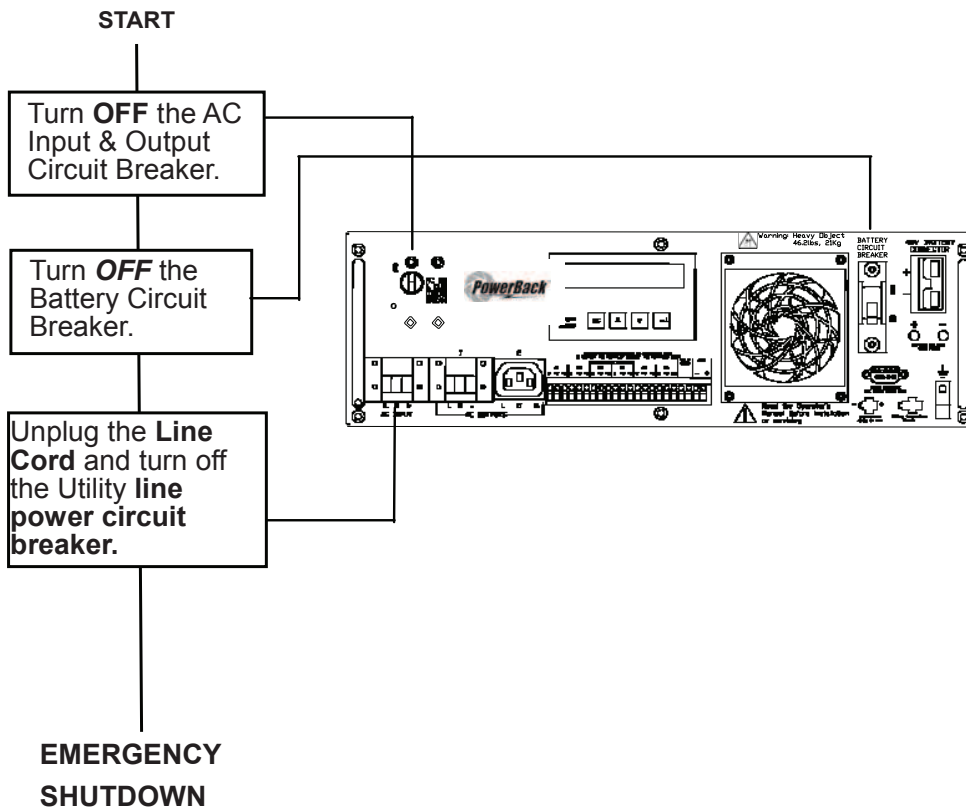

For service, parts or technical information contact:

Peek Traffic/U.S. Traffic Customer Service
2906 Corporate Way
Palmetto FL USA 34221

Phone: 1 (800) 245-7660

(941) 845-1200

Fax: (941) 845-1204

Email: tech.support@peektraffic.com

Website: www.peaktraffic.com

THIS PAGE INTENTIONALLY LEFT BLANK

PowerBack-2000ITS-E System Uninterruptible Power Supply Controller

- Section 2: Operator's Manual

THIS PAGE INTENTIONALLY LEFT BLANK



Section 2.1

Introduction

This section introduces the various features of the PowerBack 2000 UPS controller

2.1.1 The Advantages

2.1.2 A Tour of the PowerBack 2000

2.1.1 The Advantages

Advanced Power Protection Technology

PowerBack 2000 is an Uninterruptible Power Supply (UPS) controller designed for both indoor and outdoor applications. The PowerBack 2000 UPS, provides continuous power to traffic and signal equipment.

◆ **Advanced Communications**

An RS-232 port allows for remote monitoring of the PowerBack 2000.

◆ **Smart Charging**

Smart charge technology ensures the batteries are always at peak performance.

◆ **User Friendly Supervision**

The LCD panel provides “At a Glance” monitoring and control.

◆ **Service Friendly**

The batteries can be changed without shutting down the loads or the PowerBack 2000.

2.1.2 A tour of the PowerBack 2000

Purpose: Describes the connections, displays and switches on the front panel (Figures 4 5,6).

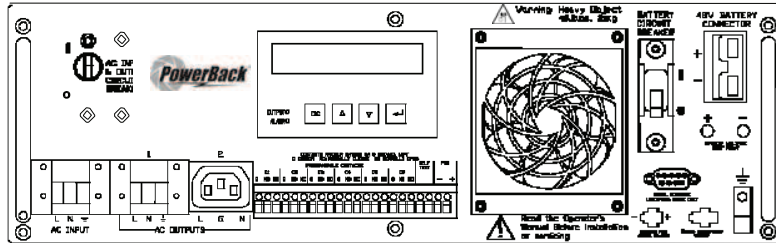
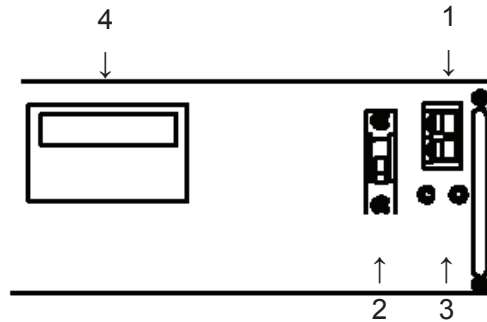

Figure 4

PowerBack 2000 Front Panel



1. 48VDC Battery Connector

It connects the battery to the unit. The battery string voltage is 48VDC.

2. Battery Circuit Breaker

It acts as an ON/OFF switch for battery power. It must be in the **ON** position for normal operation.

3. Battery Voltage Test Points

Battery Voltage can be measured at these test Jacks only when the Battery circuit breaker is turned **ON**.

TIP: TEST JACKS ARE NOT DC POWER OUTLET TERMINALS.

4. Liquid Crystal Display (LCD) Control Panel

The UPS can be controlled and monitored via this LCD Panel. See Section 2.2 for further information.

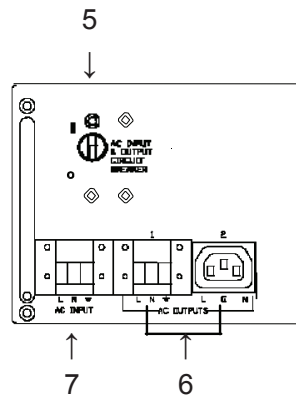

5. AC Input & Output Circuit Breaker

It acts as a line and output power ON/OFF switch to facilitate the unit's maintenance or replacement. It must be in the **ON** position for normal operation.

6. AC Output

Two set of Terminal Blocks are provided for the Output.

7. AC Input

It provides connection for the Input line Power.

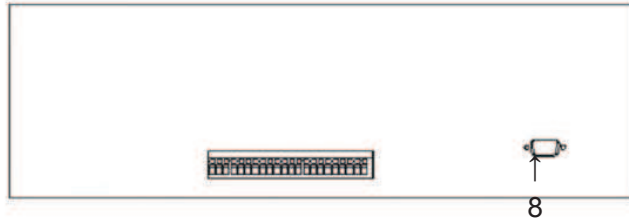

8. Serial Interface / RS232 Connector

This DB-9 female connector is used to connect the PowerBack 2000 to the host computer for remote control, monitoring and calibration via RS-232 commands. Its layout and operation is shown in Figure 5. An optional serial cable for connection to a COM port of a computer is available from the manufacturer. See section 2.3 for more details about connection and use.



Note: The interface is opto-isolated and shares a common ground with the Green Control Terminal Block.

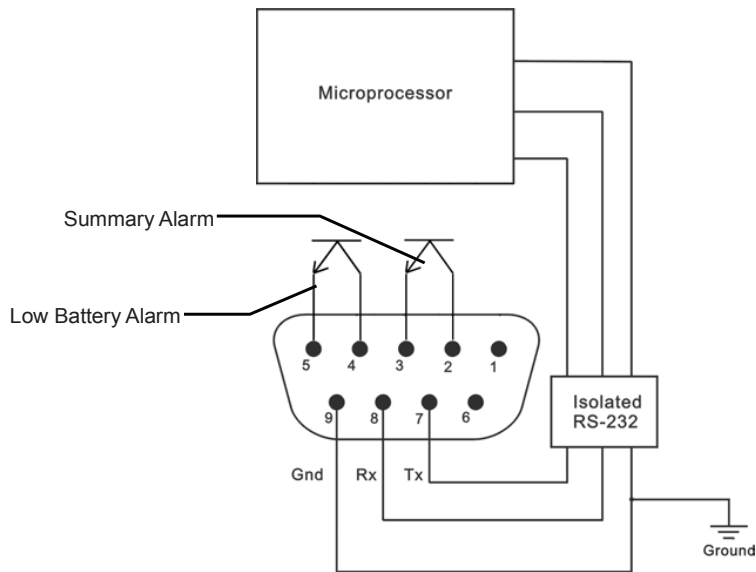
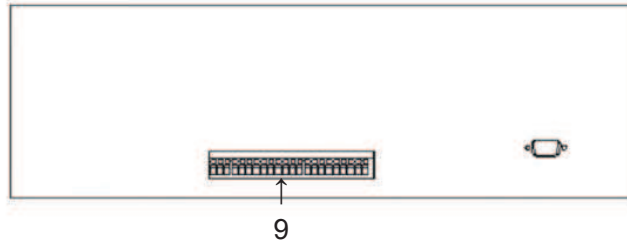

Figure 5

Serial Interface / RS232 Operation and Layout



9. Green Control Terminal Block

This 22 position terminal block provides communication with the intersection controller, controls the Power Transfer Switch (PTS) and starts the self-test. Figure 6 shows its layout and operation.



Note: This terminal block is opto-isolated and shares a common ground with the Serial Interface.

Each of the six programmable contacts can be programmed for one or more functions such as: **The Timer, Low Battery** and **On Batt**. The relay contacts are Form C type, i.e. Each of the six programmable contacts have Common (C); Normally Closed (NC) and Normally Open (NO) contact position.

- **On Batt:** This relay energizes when Utility Input line power is unqualified.
- **TIP:** When the AC Input and Output Circuit Breaker is turned **OFF**, an auxiliary switch of the circuit Breaker opens which disables the On Batt contact at the Green Control Terminal Block. This prevents the intersection lights from flashing.
- **Low Battery:** These relays energize when the battery drops below the programmed battery capacity. The default value is 47.5 or 40% Battery Capacity.
- **TIP:** You can change the preprogrammed value to match the batteries used and the actual operating conditions. See Section 2.3.4.4, "Maintenance" # 35, "Battery Voltage Level @40% of Capacity".
- **Timer:** These relays energize after the unit has been in Battery mode for programmed time. The factory default value is 2 hours.
- **TIP:** The time can be programmed to be from 15 min. to 8 hours in 15 minute increments
- **Self-Test:** To initiate self test, jumper the TB 19 & 20 at the Green Control Terminal Block.
- **PTS:** PowerBack sends a 48 VDC signal from Battery to the PTS, which activates the PTS, resulting in transfer from Input Power to Battery Power. See Section 1.3, Wiring, of this Manual for connection instructions.

Power Back 2000 Interior

Note: These Contacts have a maximum rating of 1 Amp at 240V. Only the first On Batt contact is illustrated. Rest of 5 contacts for Low Battery, Timer, etc... are similar.

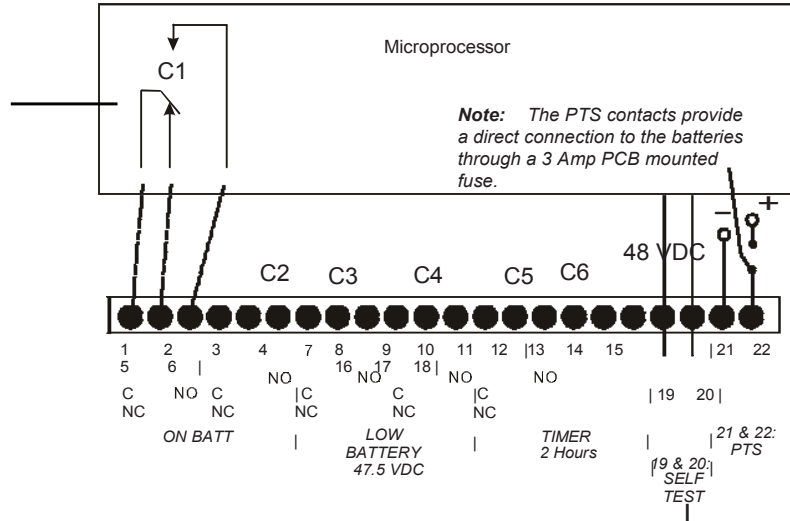

Note:

- 6 sets of programmable contact has following factory default setting:
 C1, C2 = "On Batt"
 C3, C4 = "Low Batt @ 47.5 VDC"
 C5, C6 = "Timer @ 2.00 Hours"
- User may program each of the six contacts for one or more functions. See Section 2.2 Sub Menus for more detailed information.

Note: The Self Test is performed by jumpering TB19 & 20

Figure 6
Green Control Terminal Block, Layout and Operation

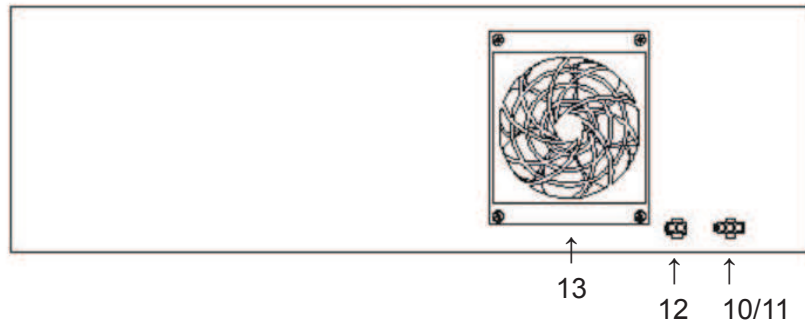

10. Battery Temperature Sensor Strain Relief

This secures the Battery Temperature Sensor cord to the panel and prevents connector disconnection during an earthquake or other severe vibrations.

First plug the sensor cable to the connector. Then use one of the ties provided in the mounting kit to attach the sensor cord to the strain relief loop. Ensure that the cable is tightened.

11. Battery Temp Sensor

It attaches the battery temperature probe to the unit for monitoring of the Battery temperature. The charging voltage is temperature dependent. The microprocessor of smart charger adjusts the voltage for optimum charging.

The probe connector **must** be plugged for normal operation. The sensor end should be firmly attached to the case of the middle battery with high strength tape.



TIP: The older version of PowerBack uses a different temperature probe. If the supplied temperature probe is not used, the charger may shut off and never charge the Batteries.

12. Ext Fan 48 VDC

It provides DC Power (48 VDC, 4Amp (Max)), which could be used to power an optional 48 VDC fan, mounted inside the enclosure for regulation of the interior temperature.

13. Internal Fan

This microprocessor-controlled fan regulates the unit's internal temperature. It must not be blocked. The filter in front of the fan is removable for cleaning.

TIP: Inspect the filter every 6 months, or as often as required. Clean by removing it, running water through the filter and air-drying before reinstallation.

Section 2.2 Operation

This section describes how to start, shutdown and operate the PowerBack 2000:

- 2.2.1 LCD panel
- 2.2.2 PowerBack 2000 Operating Modes
- 2.2.3 Self-test
- 2.2.4 Start-Up
- 2.2.5 Shutdown
- 2.2.6 Battery Replacement
- 2.2.7 LCD Menu Tree
- 2.2.8 STATUS Submenu
- 2.2.9 CONTROL Submenu
- 2.2.10 SETTINGS Submenu
- 2.2.11 MAINTENANCE Submenu
- 2.2.12 ALARM menu
- 2.2.13 FAULT menu
- 2.2.14 Event Log View
- 2.2.15 Low Battery Mode Status
- 2.2.16 Parameter Changes

2.2.1 LCD Panel

Purpose: Describes the LCD display menus (Figure 7) and use of user-friendly sub-menus (Figure 8).

- When the **Output LED** is :
- **ON**, the line is qualified and the Input Power flows to Output.
 - **FLASHING**, the unit is in Battery mode.
 - **OFF**, the Output is OFF, Input line is not qualified or the unit detected a fault.
- If **both LEDs are OFF and the LCD is BLANK**, the unit is shut off.

- When the **Alarm LED** is:
- **ON**, the unit detected a Fault.
 - **FLASHING**, the unit detected an Alarm.
- Pushing the **ENTER** button displays the problem.

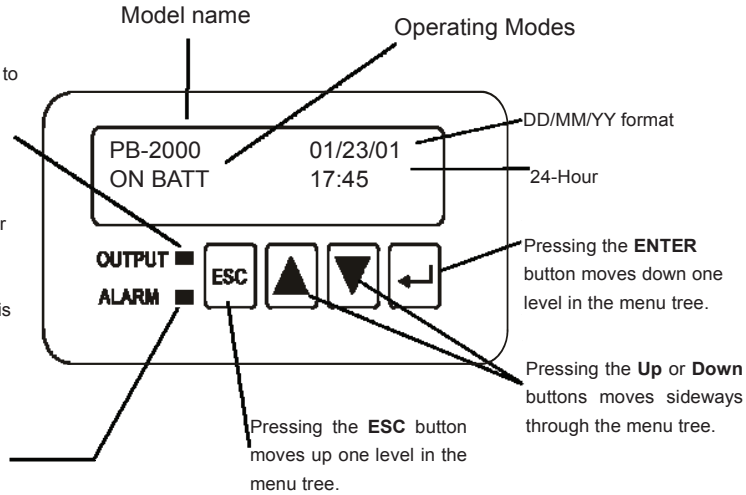

Figure 7
LCD Panel Key Functions

TIP: When the ambient air temperature drops below -20°C (-4°F), the LCD may turn DARK until the temperature rises above -20°C (-4°F). However the unit will operate normally.

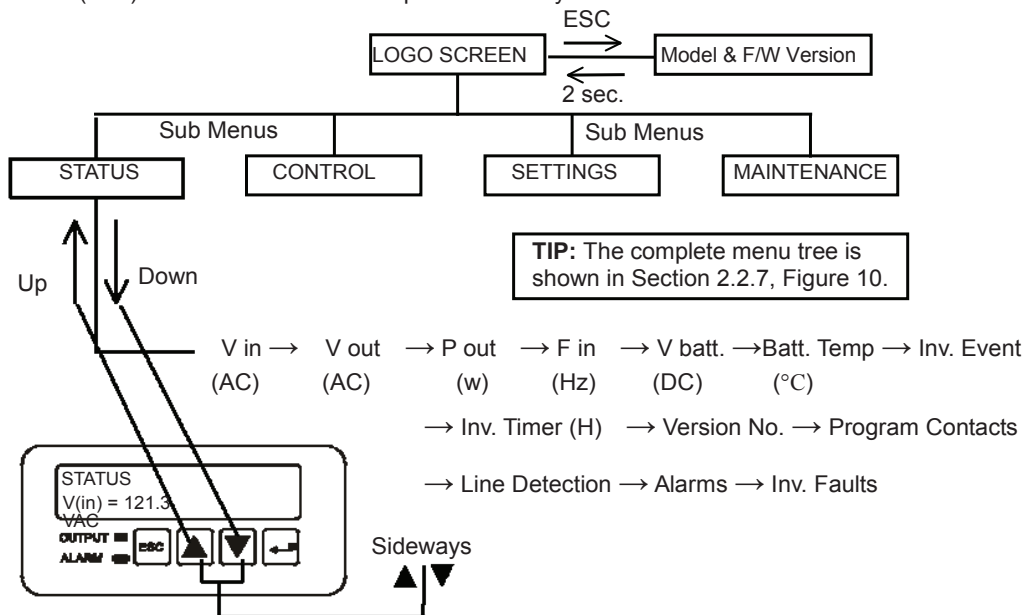

Figure 8
LCD Panel and the Menu Tree

2.2.2 PowerBack 2000 Operating Modes

Purpose: Describes the Operating modes.

TIP: The LCD automatically displays the following modes when they change.

LCD Shows	Explanation
STANDBY	This mode is displayed when the unit is first turned on. The inverter remains off and the PowerBack does not provide output power to the loads. If Input line power is qualified, it automatically switches to Line mode. To provide battery power to the loads, use the Manual On function (see Section 2.2.9)
ON LINE	The normal operating mode. Input Line power is provided to the loads, the batteries are charging and the PowerBack is ready to provide backup power.
BOOST*	The unit automatically transfers to BOOST mode to raise the low Input line voltage when output drops below the user programmable preset limit.
ON BATT	The unit automatically transfers to Battery when Input line power is unqualified. The batteries provide power to the loads.
BUCK*	The unit automatically transfers to BUCK mode to reduce the high Input line voltage when output raises above the user programmable preset limit.
SELF TEST	When "Self Test" mode is active, the unit will enter "Battery Mode" automatically to test or check if output voltage and waveform are correct, then the unit returns back to "Line Mode" in 1 minute. Users may use "Maintenance Mode" to configure longer time for self-test. Default time for self-test is 1 minute.
LOW BATT	The battery begins to discharge on "Battery mode." If the Battery voltage falls below the user programmed value (40% default setting), "Low Bat" warning appears.

* When enabled.

The following mode may be programmed by the User (see Section 2.2.10)

Sense Type (Generator / Normal Mode)

This is used to broaden the input parameters to accommodate the voltage fluctuations created by a backup generator or a noisy line.

The factory default setting is Normal, where the unit runs on Normal parameters. Switching to Generator makes it run on noisy Generator parameters.

If the unit constantly switches between Line and Battery modes due to a noisy line, select Generator mode to prevent unnecessary transfers / returns.

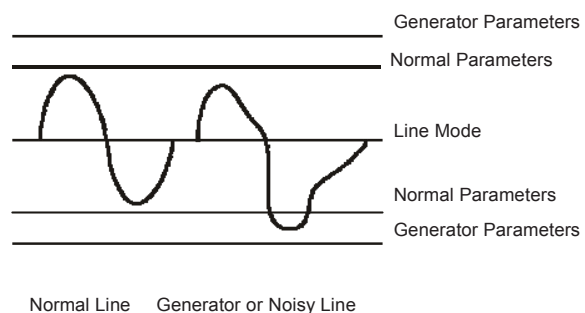

Figure 9
Normal and Generator Parameters

2.2.3 Self Test

Purpose: Describes the self-test.



Caution: This procedure should not be performed when critical loads are running that depend on the unit for backup power.

The Self Test confirms that the unit can transfer into and out of Battery mode while supporting the output load at the same time.

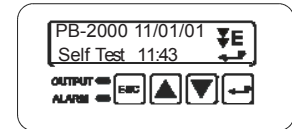

Procedure:

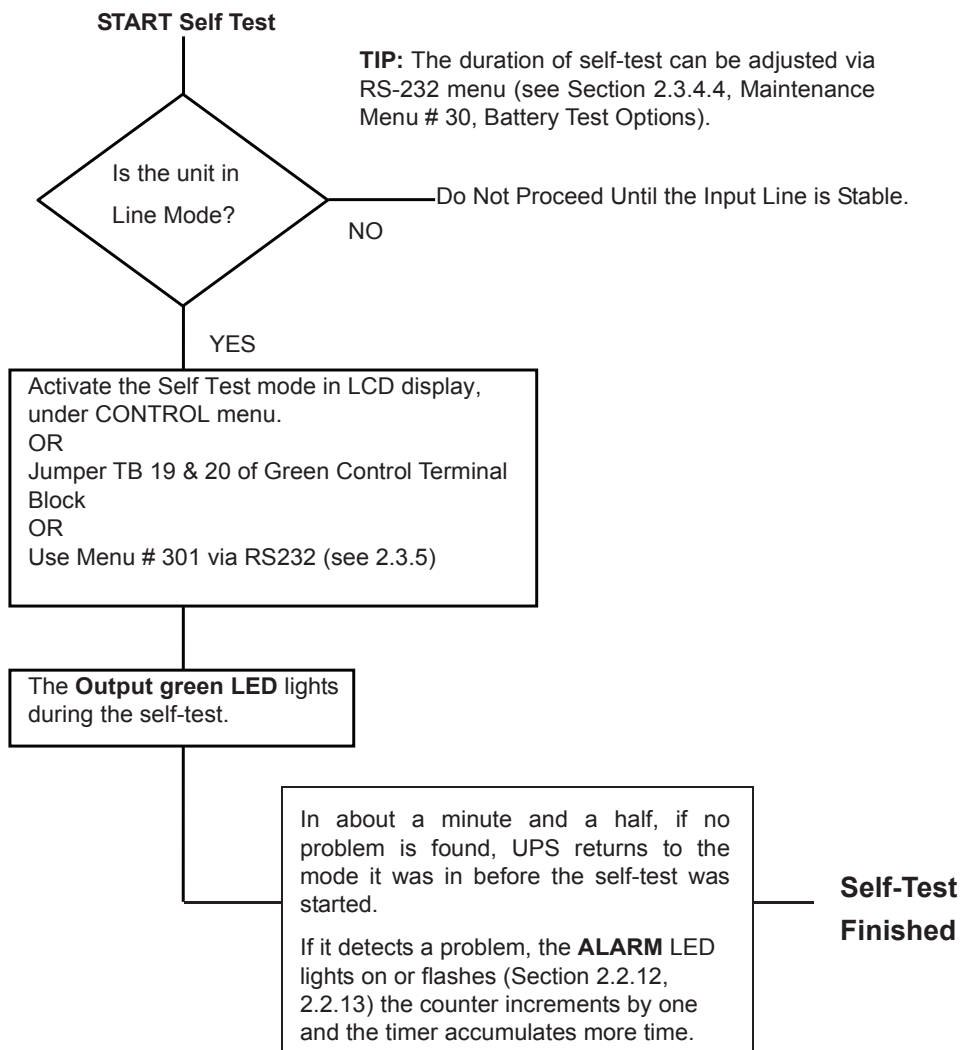

2.2.4 Start Up

Purpose: Describes the Start Up procedure.

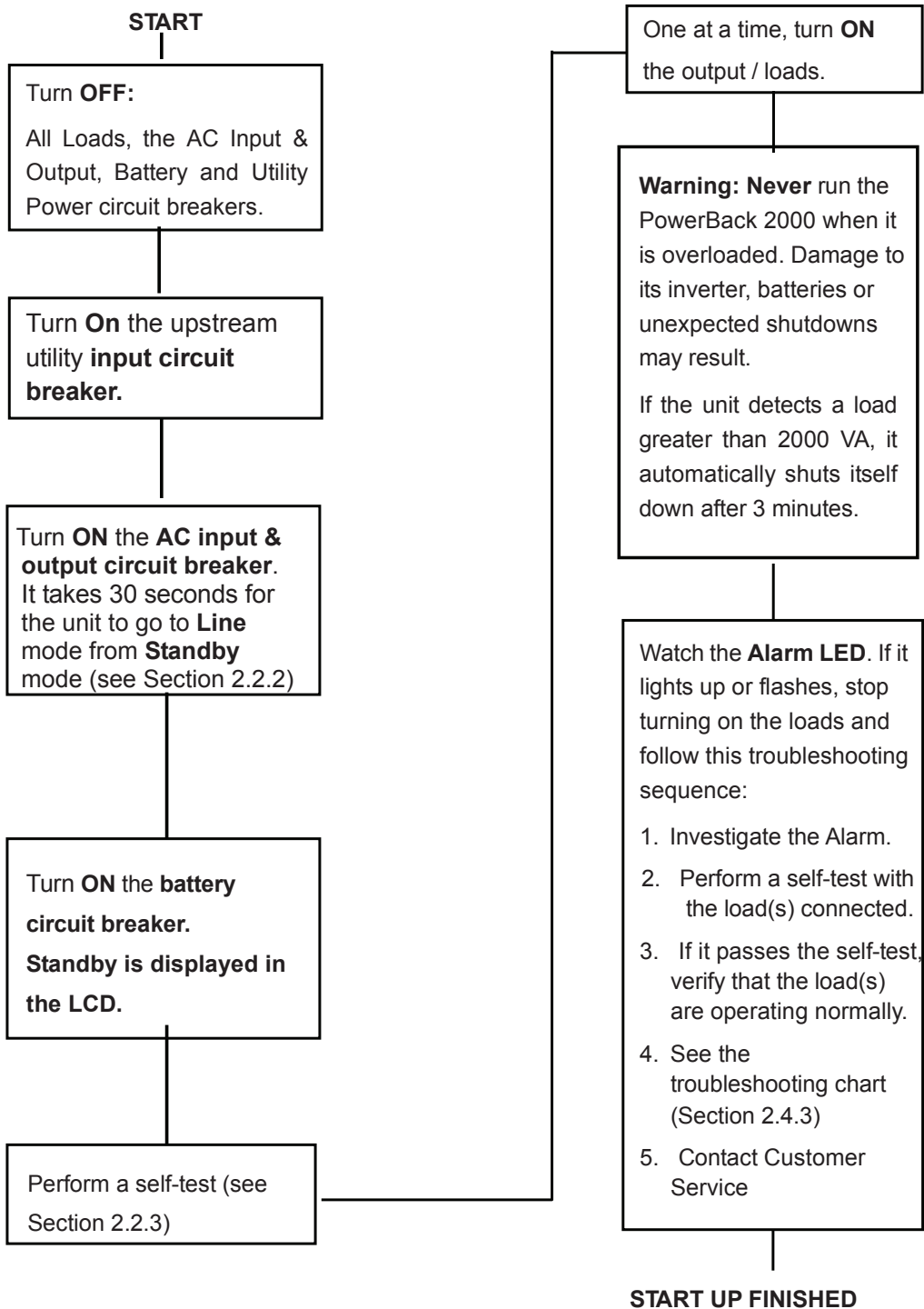

2.2.5 Shutdown

Purpose: Describes the shutdown procedure.

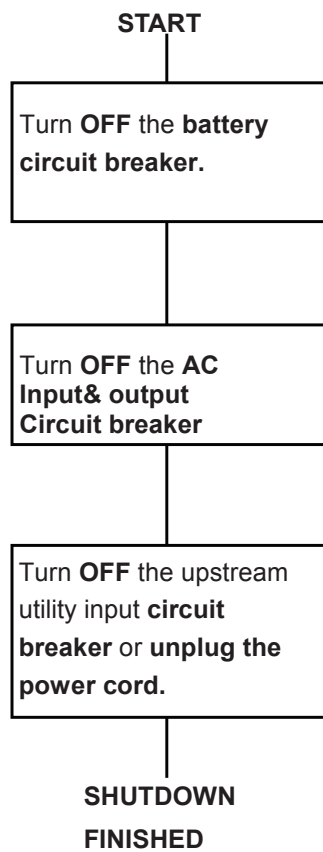

2.2.6 Battery Replacement

Purpose: Describes how to change the battery.



Caution: While the battery is being changed, the PowerBack cannot provide backup power. This procedure should not be done while critical loads are running that depend upon the PowerBack's backup power.

BATTERY CHANGING PROCEDURE

NOTE: The **ALARM LED** remains **ON** during this procedure.

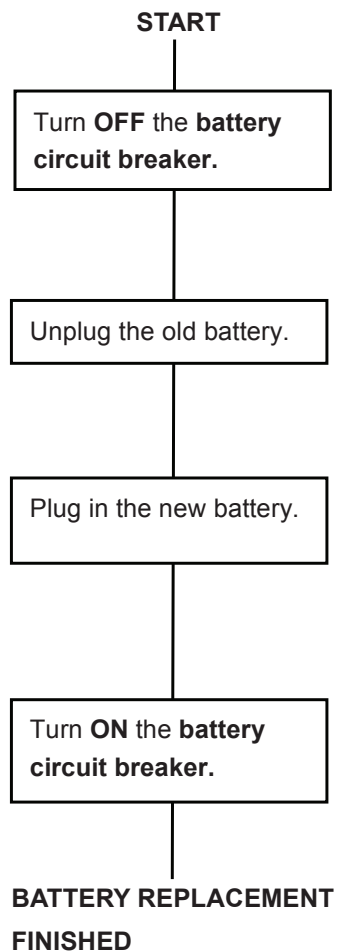

2.2.7 LCD Menu Tree

Purpose: Shows the Menu Tree (Figure 10).

TIP:

- The Alarm and Fault submenus alert the operator to a problem with the PowerBack 2000. When the **ALARM LED** is **ON** or **FLASHING**, press the **ENTER** button. One of the conditions described in Section 2.2.12 or 2.2.13 appears on the LCD.
- The status submenu provides measurements of important PowerBack 2000 inputs, output, and other parameters via the LCD (Section 2.2.8).
- The control submenu allows the operator to manage the PowerBack 2000 (Section 2.2.9)
- To learn the value of a specific measurement, when it appears on the LCD, press the **ENTER** button.
- To start a command, when it appears on the LCD, press the **ENTER** button.

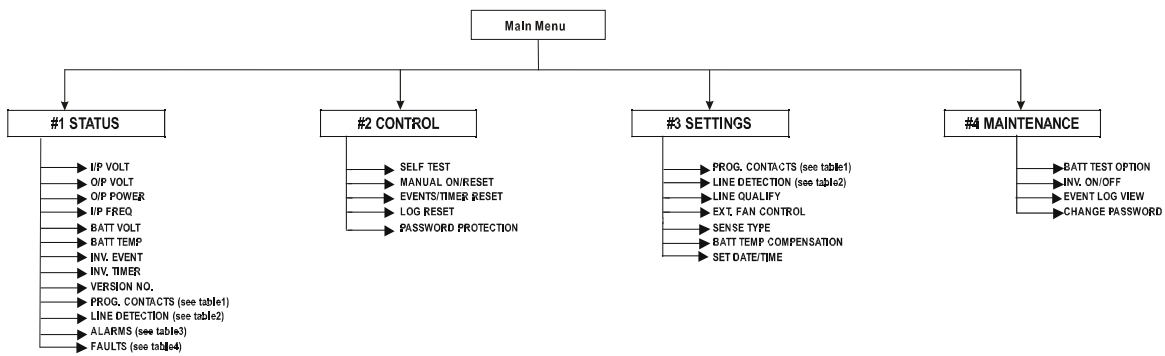

UPS STATUS (MAIN MENU)	
#0	FAULT (see TABLE 4)
#1	ALARM (see TABLE 3)
#2	HOT SWAP
#3	SELF TEST
#4	BOOST
#5	ON LINE
#6	BUCK
#7	LO BATT

TABLE 1: CONTACT FUNCTION PROGRAMMABLE CONTACTS C1-C8	
#1	ON BATT
#2	LO BATT 42.0-55.0V (0.5V increment)
#3	TIMER (0.25-8hr) (0.25 increment)
#4	ALARM any alarm, #1-#7 (TABLE 3)
#5	FAULT any fault, #1-#5 (TABLE 4)
#6	DISABLE

TABLE 2: LINE DETECTION	
#1	HIGH LIMIT 120-150
#2	HIGH HYST 120-150
#3	BUCK HIGH, 120-144
#4	BUCK LOW, 120-144
#5	BOOST HIGH, 96-120
#6	BOOST LOW, 96-120
#7	LOW HYST 90-120
#8	LOW LIMIT 90-120
#10	BOOST Feature (Setting only)

TABLE 3: ALARM INFO	
#0	NO ALARM
#1	LINE FREQ.
#2	LOW OUTPUT VOLT
#3	NO TEMP. PROBE
#4	OVER LOAD (ALARM)
#5	BATT NOT CONN
#6	HIGH TEMP
#7	LOW TEMP

TABLE 4: FAULT INFO	
#0	NO FAULT
#1	SHORT CIRCUIT
#2	BATT, LOW VOLT
#3	BATT, HIGH VOLT
#4	HIGH TEMP
#5	OVER LOAD (FAULT)

Figure 10

Note : See Section 2.2.14, For details on Event Log View under submenu Maintenance.

2.2.8 Status Menu

Purpose: Describes how to use the Status Menu to measure the input and output parameters.

Procedure: When the desired item appears on the LCD, press **ENTER** to measure it. To see the updated reading, press **ENTER** again.

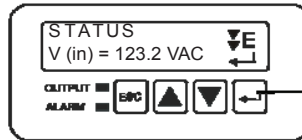

Push **ENTER** to measure the item (Input V shown)

ITEM	LCD SHOWS	DESCRIPTION
Input Voltage	STATUS V (in) = 123.2 VAC	The Utility Input line voltage.
Output Voltage	STATUS V (out) = 123.2 VAC	The output voltage (true RMS).
Output Power	STATUS P (out) = 1340 watts	The output Power (watts)
Input Frequency	STATUS F (in) = 59.3Hz	The Utility Input line frequency
Battery Voltage	STATUS V (batt) = 55.3 VDC	The average battery voltage
Battery Temperature	STATUS Batt. Temp. = +21°C	The temperature of Battery case
Inv. Events	STATUS Inv. Events = 00253	The number of times the unit has been in Battery Mode
Inv. Timer	STATUS Inv. Timer = 0242.9h	The Total amount of time the unit has been in Battery Mode since the last reset. Each decimal indicates 6 minutes (0.1 x 6 minutes). The decimal increments by 2 or every 12 minutes. For example, displayed 1.4 hours indicates that since the last reset, PowerBack has been in Battery mode for a total of 1 hour and (0.4 x 60) min = 1 hour and 24 minutes
Version No.	STATUS Version No. = 3.2/2.4	The software version used in this unit. 3.2↔Control Board, 2.4↔LCD Board
Program Contacts	STATUS Program Contacts	The Programmed values of all 6 Contacts
Line Detection	STATUS _Line Detection	The Programmed values of all input Line Detection parameters & warning levels
Alarms	STATUS Alarms	Indicates Alarms (see 2.2.12)
Faults	STATUS Faults	Indicates Faults (see 2.2.13)

2.2.9 Control Menu

Purpose: Describes how to use the control Menu to operate the unit.

Procedure: When the desired function appears on the LCD, pressing the **ENTER** button calls it up.

Many functions have more than one option available. Scroll through them by pressing the toggle buttons. When the desired option appears, pressing the **ENTER** button switches the unit to the new option.

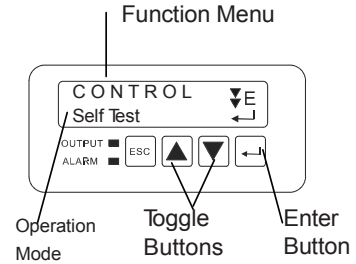

FUNCTION	ACTION	LCD SHOWS
Self Test	Pressing ENTER starts the self test [Section 2.2.3] CAUTION: The unit must be in Line Mode before starting the self-test.	
Manual On/Reset	This function is available only when the unit is first turned on and the LCD shows Standby. Pressing ENTER manually starts the unit and the battery supplies the output power.	
Events/Timer Reset	Press ENTER when the LCD displays the message. <i>This resets the event and timer counters to zero.</i>	
Log Reset	Press ENTER when the LCD displays the message. <i>This clears all the messages from the Event Log.</i>	
Password Protection	This feature allows user to control the access of the Maintenance Menu with or without the password. When the Password access to the Maintenance Menu is Enabled here, the Maintenance Menu can ONLY be accessed when the correct Password is entered. When the Password access to the Maintenance Menu is DISABLED here, the Maintenance Menu can be accessed without the Password.	

2.2.10 Settings Menu

Purpose: Describes how to access and program various critical parameters.

Procedure: When the desired function appears on the LCD, pressing the **ENTER** button calls it up.

Many functions have more than one option available. Scroll through them by pressing the toggle buttons. When the desired option appears, pressing the **ENTER** button switches the unit to the new option.

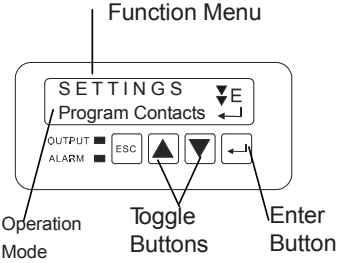

FUNCTION	ACTION	LCD SHOWS
Program Contacts	Indicates Programmed values of all 6 Contacts	
Line Detection	Indicates Programmed values of all input Line Detection parameters & warning levels	
Line Qualify	Indicates setting for AC recovery time. Selections are 3 sec, 10 sec, or 30 sec. Default recovery time is 30 sec.	
Ext. Fan Control	Indicates temperature setting for fan inside the PB-2000.	
Sense Type	Toggle between Generator [Generator parameters] and Normal [Normal parameters]. This broadens the unit's input parameters to accommodate the fluctuations created by a generator or noisy line	
Batt Temp. Comp.	<p>This adjusts the battery charging temperature compensated voltage to $-3 / -4 /$ or $-5 \text{ mV}/^{\circ}\text{C}/\text{Cell}$.</p> <p>Consult the manufacture's specifications to find out which setting is best suited for your batteries. The factory default setting is $-3 \text{ mV}/^{\circ}\text{C}/\text{Cell}$.</p>	

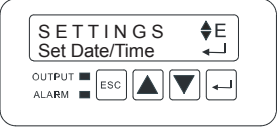
Set Date/Time	Sets date and time.	
----------------------	---------------------	---

2.2.11 Maintenance Menu

Purpose: Describes how to access, and view and modify various parameters for the maintenance.

This Menu is normally used ONLY by the qualified person, hence the Password protection option is provided to access this Menu.

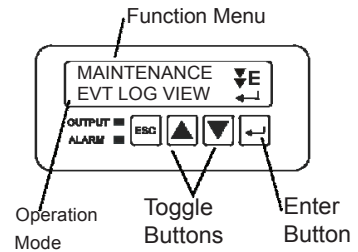

FUNCTION	ACTION	LCD SHOWS
Enter Password	<p>If Password access is Enabled in CONTROL Menu, then it must be entered here before the Maintenance Menu can be accessed.</p> <p>Use the UP / DOWN arrow key with ENTER keys to enter a correct Password. Reentry is required if an error is made entering a Password.</p>	
Battery Test Option	<p>Battery Test Option can be verified here. Battery Test period of 1 to 255 minutes can be selected here in 1 minute increments.</p> <p>The PowerBack can be tested to run on Battery for Maintenance purposes here.</p>	
Inverter On/Off	<p>Inverter can be turned ON or OFF. This option is available ONLY when the PowerBack is in Battery or Standby Mode.</p>	
Event Log View	<p>The Event Log with date & Time is viewed here in Binary digital format. See section 2.2.14 for details.</p>	
Change Password	<p>The Password for access to the Maintenance Menu is changed here.</p> <p>Use the UP / DOWN arrow key with ENTER keys to enter a correct Password. Reentry is required if an error is made entering a Password.</p>	

2.2.12 Alarm Menu

Purpose: Describes the Alarm Menu and how to use the LCD for troubleshooting. (Figures 11, 12 and 13)

Procedure:

When the **red ALARM LED** is **FLASHING**, the unit has an alarm, a condition not serious enough to stop it from providing output power. Press **ENTER** to see the alarm.

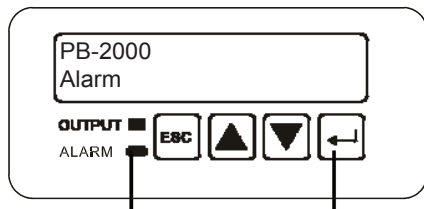

1. Red Alarm LED FLASHING 2. Press ENTER

Figure 11
LED Shows an Alarm

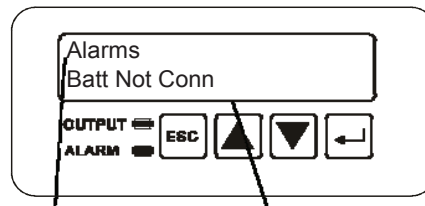

3. Unit has ALARM condition 4. Type of alarm, e.g. Battery is Not Connected. see fig 13 below for various alarms for Alarm menu.

Figure 12
LCD Displays the Alarm

LCD SHOWS	Alarm	DESCRIPTION
Line Freq	Line Frequency	The Input frequency is fluctuating & out of tolerance.
Low O/P Volt	Low Output Voltage	The output voltage is low, but still usable.
No Temp. Probe	Temperature Probe Unplugged	The battery temperature probe is unplugged or damaged. When the unit detects the probe is unplugged, it will continue to operate, but the charger voltage will automatically be set to the lowest value.
Over Load	Overload	The loads are drawing more power from the PowerBack 2000 than it can provide.
Batt Not Conn	Battery Not Connect	The Battery is not connected.
High Temp	High Temperature	The battery temperature is high.
Low Temp	Low Temperature	The battery temperature is low.

* The alarms are self-resettable. After the alarm condition is removed, the unit automatically returns to Line mode if the line is qualified, or Battery mode if it isn't.

Figure 13
Alarm Table

2.2.13 Fault Menu

Purpose: Describes the Fault Menu and how to use the LCD for troubleshooting. (Figures 14, 15 and 16)

Procedure:

When the red **ALARM LED is continuously ON**, the unit has a fault, a condition where backup power is unavailable. Press **ENTER** to learn the problem.

TIP: When the unit has a fault and Input line power is qualified and available, the output loads are directly connected to the Input line with no line conditioning or backup power provided.

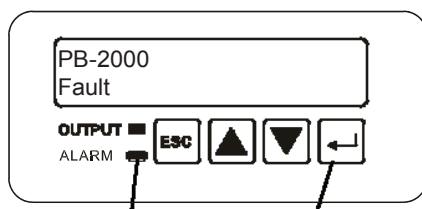

1. Alarm LED on steady
2. Press ENTER

Figure 14
LED Shows a Fault

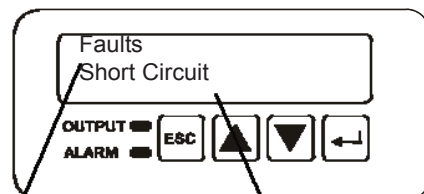

3. Unit has FAULT
4. Type of fault (e.g. short Circuit). See fig. 16 below for various faults.

Figure 15
LCD Displays Fault

LCD SHOWS	FAULT	DESCRIPTION
Short Circuit	Short Circuit	The load is short-circuited or the inverter did not start.
Batt. Low Volt	Low Battery Voltage*	The battery's output voltage is low.
Batt. High Volt	High Battery Voltage	The battery's output voltage is high.
Temp High	High Temperature*	The battery's temperature or the PowerBack 2000 internal temperature is high.
Over Load	Overload	The loads are drawing more power than the PowerBack 2000 can provide.

*These faults are self-resettable. After the fault condition is removed, the unit automatically returns to Line mode if the line is qualified, or Battery mode if it isn't. For the other faults, the unit is reset by shutting it down and restarting, using AC & Battery Breakers. The faults can also be reset in the Control Menu of the LCD display.

Figure 16
Fault Table

2.2.15 Low Battery Mode Status

Purpose: Describes the various states of the Low Battery Mode (Figure 17).

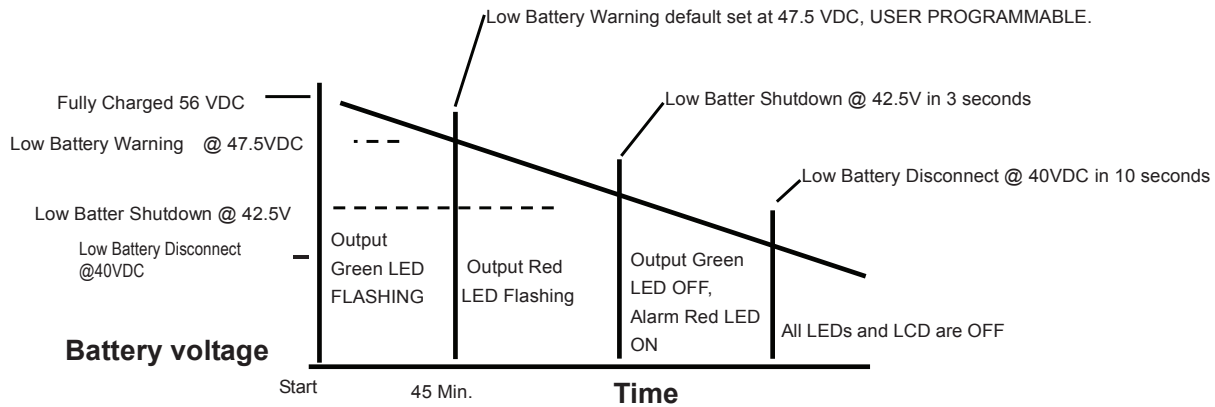

Figure 17
Low Battery Modes Status

Note: Not to scale. All values are shown for illustrative purpose *only* and will **change under different operating and battery conditions**. Actual times will be different. Perform a run time test (Section 2.4.1) for your operating conditions.

Low Battery Warning

The Batteries still power the loads, but they are almost discharged and cannot power them much longer.

TIP: The operator should shut down unnecessary loads to extend battery backup time.

Low Battery Shutdown

When the battery decreases to 42.5 VDC for 3 seconds, the unit automatically shuts output OFF and goes into SLEEP mode awaiting for Input Power to return. The batteries are considered fully discharged and can no longer power the load, but they have enough power to keep the unit's monitoring and control circuits active. The housekeeping power supply is kept alive.

Low Battery Disconnect

When the battery discharges to 40 VDC for 10 seconds, the unit automatically goes into this mode. The batteries are disconnected from the unit to protect them from damaging via deep discharge. Both LEDs and the LCD shuts OFF, showing the unit is shut off. The unit stays off until line power or a backup generator is available or fresh batteries are connected.

2.2.16 Parameter Changes

All parameter changes should be performed by authorized personnel as it will affect the performance of the traffic intersection.

THIS PAGE INTENTIONALLY LEFT BLANK

Section 2.3

Communication

This section describes how to communicate with PowerBack 2000 using any Personal computer via RS-232 communications:

- 2.3.1 RS-232 set-up
- 2.3.2 HyperTerminal set-up
- 2.3.3 The main menu.
- 2.3.4 Menu Tree & the sub menus.
- 2.3.5 Menu Tutorial.

2.3.1 RS-232 set-up

Purpose: Describes how to set-up communication between any PC and PowerBack 2000 using RS232. The wiring and software set-up is detailed below.

When the DB-9F, a female connector at front panel is connected to a PC with Windows 3.1, 9X, or terminal emulation software, the PowerBack 2000 can be remotely monitored, controlled and calibrated using RS-232 ASCII commands.

2.3.1.1 RS232 Connector at PowerBack

Pin Assignments for a 9 pin socket / Female

Connector located at PowerBack's front panel.

Pins 1 & 6: Do Not connect to RS-232

Pin 2: Summary Alarm (Opto-isolated)

Pin 4: Low Battery Alarm (Opto-isolated)

Pin 7: Txd (RS-232 Transmit)

Pin 8: Rxd (RS-232 Receive)

Pin 3,5,9: GND (Logic ground for RS-232)

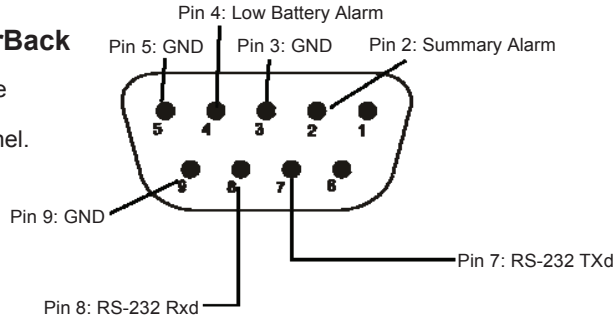

Figure 18
DB-9F Pin Out Diagram

2.3.1.2 RS232 cable

A 9 pin or 25 pin RS232 cable, wired as below can be ordered from factory as an optional accessory.

This cable allows local and remote communication between PowerBack 2000 and any PC. One end of the RS232 cable connecting PowerBack 2000 must be DB-9M, a Male / Plug connector as shown.



NOTE: Use *only* fully shielded cables for the connections.

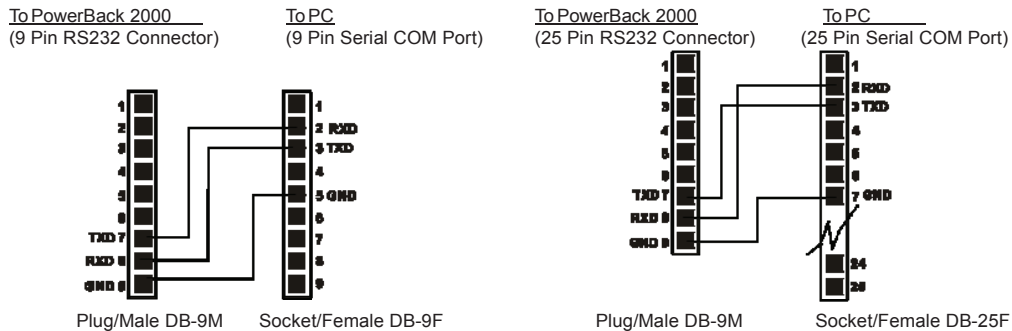
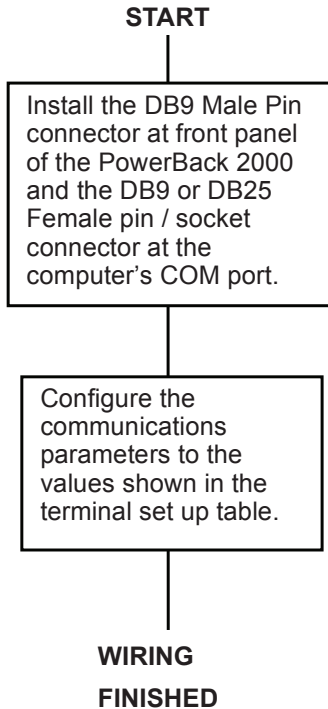

Figure 19
DB-9 Wiring

2.3.1.3 Wiring Set-up Procedure



TERMINAL SET UP TABLE	
Emulation Type	VT 100 or Compatible
Duplex Mode	Half Duplex
Xon/Xoff Flow Control	NONE
RTS/CTS Flow Control	OFF
Line Wrap	ON
Screen Scroll	ON
CR Translation	CR
Back Space	N/A (See Note)
Break Length	N/A
Inquiry	N/A
COMMUNICATION PARAMETERS	
Handshaking	Software Handshaking
Baud Rate	2400 bps
Data Format	8 Bit Data, No Parity, 1 Stop Bit

TIP: The **Backspace** and **Delete** keys are ignored by the program. If a command is wrong, press **Enter** and retype the command.

TIP: In Windows 3.1, click the Terminal icon. In Windows 95/98 the path is Start/Programs/Accessories/Communication/HyperTerminal.

For a tutorial on how to connect the unit with Window's HyperTerminal, see Section 2.3.2, "HyperTerminal Set Up."

2.3.2 HyperTerminal Set Up

Purpose: Describes how to set up PowerBack's RS-232 port using Windows® 95/98's HyperTerminal program (see figures 20 to 27)

The following HyperTerminal setting is recommended for local or remote communication between PowerBack & PC. For this tutorial, Com 1 is used. Verify the designation of COM port, where RS232 cable to PC is connected as shown in 2.3.1.2 such as COM1, COM2, etc..

Step 1: The path is **Programs/Accessories/Communications/HyperTerminal** as shown on Figure 20.

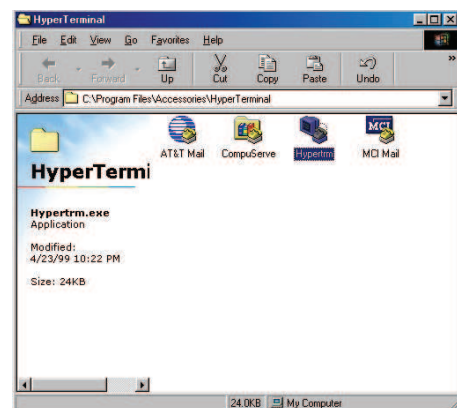

Figure 20

Step 2: Click on the **Hypertm.exe** icon. **The connection Description** screen (Figure 21) appears as shown.

Enter a name and icon for your unit and click **OK**.

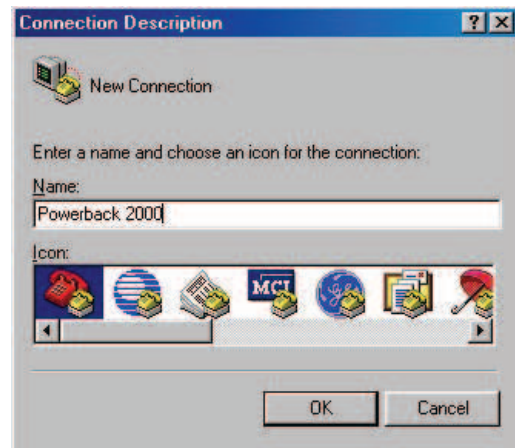

Figure 21
Connection Description Screen

Step 3:

The **Connect To** screen (Figure 22) appears.

Select the COM port that will be used from the drop down menu as shown.

Click OK.



Figure 22
Connect To Screen

Step 4: The **COM Properties** screen appears (Figure 23). Select the port settings as shown.

Step 5: Click the **Advanced** button.

* PB2000ITS Inverters with a manufacture date of 3/04/04 or later use a baud (Bits per second) rate of 2400

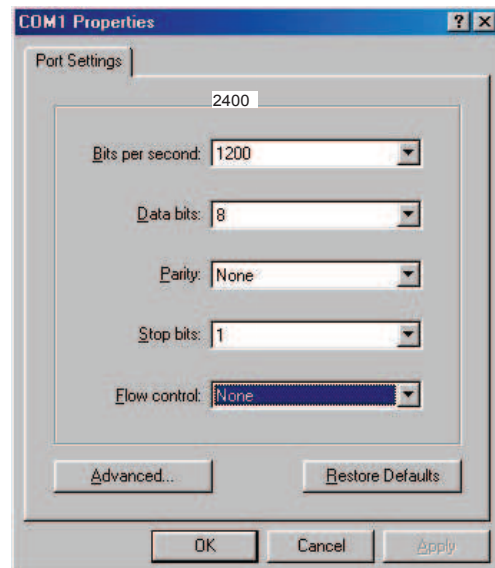

Figure 23
COM Properties Screen

Step 6: In the **Advanced Port Settings** screen (Figure 24), Select the fields as shown.

NOTE: The “Use FIFO buffers” only applies to computers with 56Kbs modems or faster. For slower connections, leave it unchecked.

Click **OK**.

The **COM Properties** Screen reappears (Figure 23). Click **OK**.

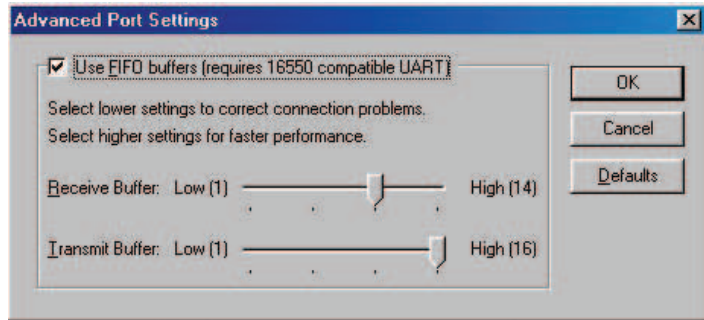

Figure 24
Advanced Port Settings Screen

Step 7: A blank window with the entered file name appears (figure 25).

In the **File** menu, go to **Properties** and **Click**.

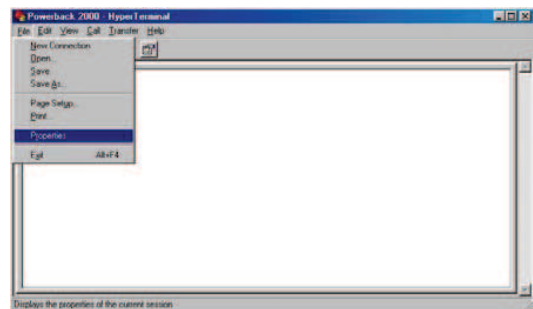

Figure 25
PowerBack's Screen

Step 8: The *[Name of Unit]* Properties screen appears (Figure 26).

Click on the **Settings** Tab. Select the fields as shown.

Step 9: Click the **ASCII Setup** button.

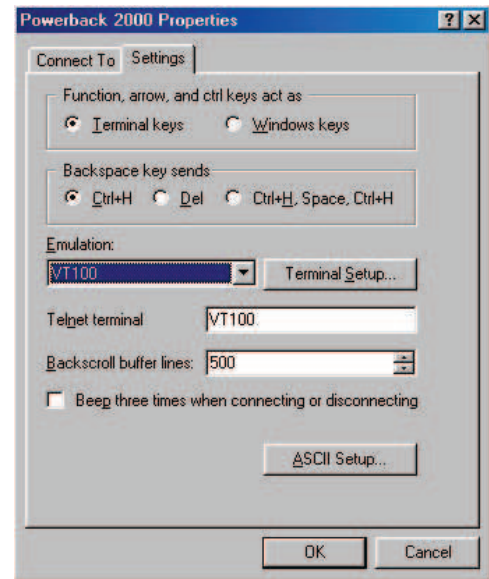

Figure 26
Properties Screen

Step 10: Select the fields in the **ASCII Setup** screen (Figure 27) as shown.

Step 11: Click **OK**. The *[Name of Unit]* properties window (Figure 26) reappears.

Step 12: Click **OK**.

HyperTerminal setup is completed.

Press **Enter** to go to PowerBack's screen (Figure 25).

Press **Enter** to access the unit via RS-232 communications.

The Main Menu (Figure 28) appears.

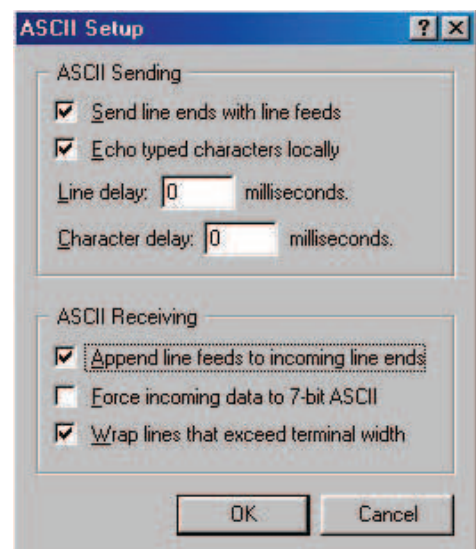

Figure 27
ASCII Setup Screen

2.3.3 Main Menu

Purpose: Describes the Main Menu (Figures 28 to 31).

The RS-232 menus are hierarchical. The top-level menu, the main menu (Figure 28), is accessed by pressing **Enter**.

Figure 32 shows the menu tree.

The main menu displays the sub menu numbers, the line status, the unit's output status and any faults or alarms that may be present.

TIP: The factory set default password **1111** is required to access and set many functions, such as in menu 34 & menu 5.

Procedure:

To access a particular sub menu, type in the sub menu number and press Enter. To update the screen, press **Enter**.

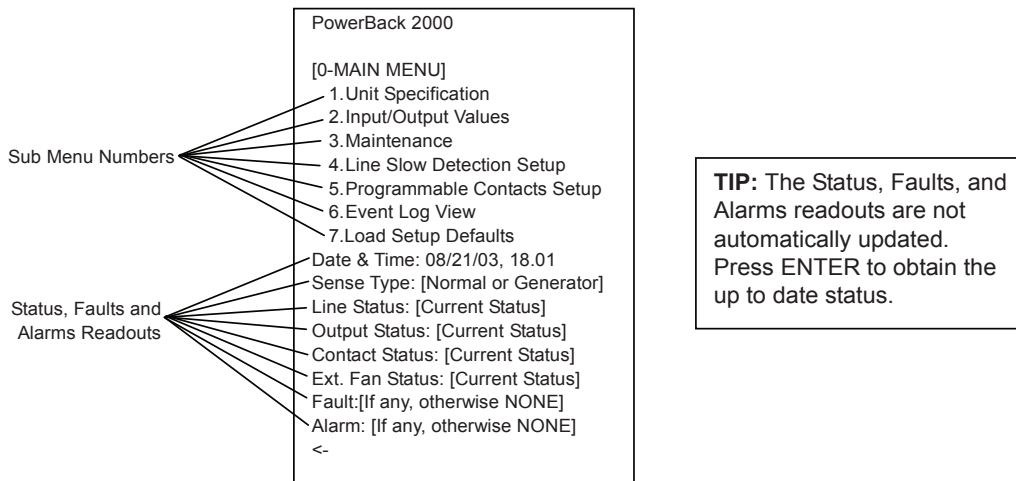

Figure 28
Main Menu Screen

Tabulation of various items that appears under the Line Status, Output Status, Faults and Alarms are shown in Figures 29, 30, and 31.

Line status: [Current Status] Output status: [Current Status] Content Status: [Current Status] Ext. Fan Status: [Current Status] Faults: [If any, otherwise blank] Alarms: [If any, otherwise blank] >_	LINE STATUS	
	Normal	Input power is normal.
	Boost	Input power is out of tolerance. Boost mode is activated.
	Buck	Input power is out of tolerance. Buck mode is activated.
	Blackout	Input voltage is not available.
	Low	Input voltage is lower than programmed low limit.
	High	Input voltage is higher than programmed Hi limit.
	Freq low	Input frequency is too low. (<55 Hz)
	Freq high	Input frequency is too high. (>65 Hz)

Figure 29

Line Status Displays

Line status: [Current Status] Output status: [Current Status] Content Status: [Current Status] Ext. Fan Status: [Current Status] Faults: [If any, otherwise blank] Alarms: [If any, otherwise blank] >_	OUTPUT STATUS
	Line mode
	Inverter mode
	Inverter mode. Low bat, warning
	Inverter mode (testing battery)
	Boost mode
	Buck mode
	Hot swap mode
	Shutdown due to fault
	Shutdown due to low battery
Shutdown due to no line	

Figure 30

Output Status Displays

<p>Line status: [Current Status]</p> <p>Output status: [Current Status]</p> <p>Content Status: [Current Status]</p> <p>Ext. Fan Status: [Current Status]</p> <p>Faults: [If any, otherwise blank]</p> <p>Alarms: [If any, otherwise blank]</p> <p>>_</p>	Fault Displays	
	Short-Circuit	Output Short Circuit
	Vout_Hi	Output Voltage High
	Vbat_Hi	Battery Voltage High
	Vbat_Lo	Battery Voltage Low
	Temp_Hi	Ambient Battery Temperature High or Internal Temperature High
	Lout_Hi	Output Current High
	EEPROM_ERROR	Error Reading EEPROM
	Wout_Hi	Output Power High (Overload)
	Bad_Battery	Bad battery
	ALARM DISPLAYS	
	Vout_Lo	Output Voltage Low
	Lout_Hi	Output Current High
Overload	Output Overload	
Temp_Hi	Ambient Battery Temperature High	
Temp_Lo	Ambient Battery Temperature Low	
PLL	Phase Lock Loop Cannot Lock with Input	
Line_Freq	AC Line Frequency High or Low	
Tmp_Probe_disconnect	Temperature probe uninstalled or disconnected.	
Batt_Brk_Off	The battery breaker is off or the batteries are discharged.	

Figure 31
Fault and Alarm Displays

2.3.4 Menu Tree & RS232 sub menus

Purpose : Describes the RS-232 Menu Tree and the unit Specifications, Input/Output Values, Maintenance and Line Slow Detection Setup Sub Menus (Figures 32 to 37)

2.3.4.1 RS-232 Menu Tree

The complete MENU Tree is shown on the next page with all default values.

Press ENTER to
go back to the
Main Menu

TIP: To access any item from the Main Menu. Type in the
function number and press ENTER.

2.3.4.2 Unit Specifications, Input/Output Values

Menu 1 below (figure 33) lists the PowerBack's specifications.

Procedure: At the main menu, type **1** and press Enter. The screen displays the Unit Specifications as shown below. To return to the main menu, press **Enter**.

[1-Unit Specifications]		
Unit Model	PB-2000ITS-E	The model name
Unit Freq	50/60 hertz	Nominal operating frequency
Input Voltage	240 Volts	Nominal Input voltage
Output Voltage	240 Volts	Nominal output voltage
Output VA	2000 VA	The output VA capacity
Battery Voltage	48 Volts	Nominal Battery voltage
Max Charge Current	10 amps	MAX charge capacity
EEPROM Version	3.1	EEPROM version of the PowerBack

Figure 33

Unit Specifications Menu

2.3.4.3 Input / Output Values

Menu 2 below (figure 34) lists the actual measurements of various input / output parameters.

Procedure: At the main menu, type **2** and press Enter. The screen displays the Unit Specifications as shown below. To return to the main menu, press **Enter**.

[2- Input/Output Value]		
INPUT		
Voltage	240 Volts	The Input voltage
Freq	60.1 Hertz	The Input frequency
OUTPUT		
Voltage	240 Volts	The output voltage
Freq	60.1 Hertz	The output frequency
Power	0000 Watts	The output Power in watts
BATTERY		
Temperature	25 °C	The ambient temperature of the battery case as read via attached temperature probe..
Voltage	53.8 Volts	The Battery DC Voltage.
Evt/Timer		
Inv Event	00012	The numbers of Input Power Failures.
Inv Timer	13 Hours 36 Minutes	Total time that the Battery was Discharged since the last RESET.

Figure 34

Input/Output Values Menu

2.3.4.4 Maintenance

Menu 3 below (Figure 35) lists the various maintenance options.

Procedure

At the main menu, type 3 and press ENTER. The Maintenance Menu shown below is displayed. To return to the main menu, press ENTER.

[3 – Maintenance]	
30 Battery Test Options	<p>The start - stop for the Battery Test / Self Test is initiated here. The test duration is user programmable in 1 minutes interval from 1 to 255 minutes. The factory default setting is 1 minute.</p> <p>Tip: The time duration can be changed only in the line mode.</p>
31 OUTPUT SHUTDOWN	<p>This allows output to be switched OFF or Shutdown. PowerBack switches to STANDBY mode when this option is activated.</p>
32 INVERTER ON/OFF	<p>During the BATTERY or STANDBY mode, this option allows the inverter to switched OFF or turned ON after the user programmable delay time.</p> <p>The delay can be user programmable in 0.5 seconds steps from 0 to a maximum setting of 255 steps (128 seconds). The delay is only available in Standby or Battery modes. When the unit returns to line mode, the delay resets back to a default of 0 seconds.</p> <p>Thus during a battery discharge or ON BATTERY mode, operator can stop the inverter immediately after user programmable delay time of 0 seconds to a maximum of 300 seconds, prior to making the intersection dark.</p>
33 CHANGE PASSWORD*	<p>This option allows for the change of password. The factory set default password is 1111.</p> <p>Tip: It can only be changed in line mode.</p>
34 LINE QUALIFY TIME	<p>When the input power returns and it is qualified, i.e. it is within acceptable range, the retransfer from Battery mode to Line mode is delayed by user programmed 3 / 10 / 30 seconds herein that allows the returned line to settle down. The factory set default value is 30 seconds.</p>
35 BATTERY VOLTAGE LEVEL % Capacity Remaining	<p>The level for LOW BATTERY ALARM as well as the activation of Normally Open relay contact at pins 4 & 5 of RS232 connector is set here.</p> <p>The Voltage level is user programmable in 0.5 VDC increments from 42 VDC to 55 VDC. The factory default setting is 47.5 VDC or 40%). The relationship between Remaining % capacity of Battery and its DC Voltage depends on the characteristics of the batteries used.</p>

36 Load Shed Timer ON/OFF (available in Battery Mode only)	The programmable Timer contacts are Manually activated / deactivated ON DEMAND using this option. Certain Loads / Signals connected to this Timer can be shed or dropped earlier to extend the Back-up time. This function is available only in "Battery Mode".
37. Reset The Event/Timer Counters (available in Line Mode)	Resets Event to 0. Resets Timer to 0.
38. Battery Charging Temperature Compensation	Temperature compensated smart charger is utilized in PowerBack. The rate of charging is adjusted here based on the Battery case temperature. The factory default value is set at -3mv/deg °C /Cell. It can be configured to -3 / -4 / -5 mv/deg °C/Cell.
39. Ext. Fan on/off by Temperature	Set the temperature in °C, above which the 48 VDC power will be provided for external cooling fan. The temperature can be set in 1°C increment from 20 to 55 °C. The factory default temperature is set at +25°C.

Figure 35

Maintenance Menu

***Password Changing Procedure**

1. Go to Menu 33.
2. Type the current password (the factory set password is 1111) and press **Enter**.
3. The words " Enter New Password" appear on the screen. Type the new password (any combination of 4 digits) and press **Enter**.

NOTE: The password can be four digits ONLY – NO LETTERS.

4. The words "Re-enter new Password" appear on the screen. Retype the new password and press **Enter**.

If the wrong password is retyped, the screen displays " Error in entering data... please try again." Type the correct password and press **Enter**.

If the retyped password is correct, the screen returns to the main menu.

For a tutorial on how to use the menu screens, see Section 2.3.5.

2.3.4.5 Line Slow Detection Parameters

This option allows user to change various detection and warning levels for input AC voltages, qualified and unqualified values, Transfer & Retransfer set points for going in & out of Battery mode / Boost / Buck modes. The factory set default values concurs with those specified by major DOTs (Department of Transportations). See Figure 37 for a description of each parameter.



CAUTION: Improperly set parameter values can cause **permanent damage** to the unit and they should only be changed by manufacturer- trained personnel.

Contact Customer Service before making any adjustment.

2. 3.4.4.1 Parameter Change Procedure

1. Go to the Menu 4.
2. “ Enter Password” appears (the factory set password is 1111), Type the password and press **Enter**.

If the wrong password is typed, the screen displays “ Error in entering data... please try again.” Type the correct password.

3. The Parameter Change Screen appears (Figure 36). Type the new value that is within the range of acceptable parameter limits and press **Enter**.

The screen returns to the Line Slow Detection Screen. For example:

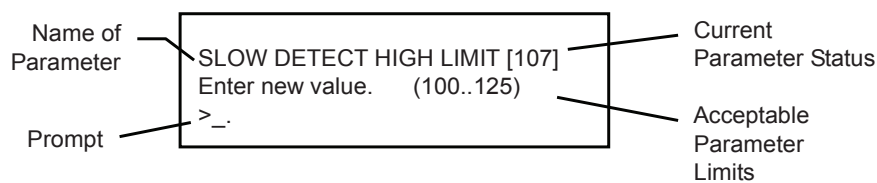

Figure 36

Parameter Change Screen
(Slow Detect High Limit Screen Shown)

For a tutorial on how to use the menu screen, see Section 2.3.5

2.3.4.4.2 Parameter Descriptions (Some levels are user programmable. Factory default settings depend on rating voltage.)

		Factory Default Settings	RANGE
<p>40 Slow Detect Hi Lmt When input voltage exceeds this level, PowerBack Transfers to Battery Mode from either Buck mode (when enabled) or Line mode.</p>	<p>On Battery Mode Buck to Battery</p>	<p>242 252 VAC 262</p>	<p>230~242 240~252 VAC 250~262</p>
<p>42 Slow Detect High Hyst When input voltage returns below this level, PowerBack Retransfers back to the Line mode from Battery mode.</p>	<p>Battery to Buck</p>	<p>236 246 VAC 256</p>	<p>224~236 234~246 VAC 244~256</p>
<p>46 Slow Detect Buck High When input voltage exceeds this level, PowerBack transfers to Buck Mode (only when enabled) reducing the output.</p>	<p>Line to Buck</p>	<p>230 240 VAC 250</p>	<p>Fixed</p>
<p>47 Slow Detect Buck Low When input voltage returns below this level, PowerBack Releases the Buck mode (when enabled) and transfers back to the Line mode.</p>	<p>Buck to Line</p>	<p>224 234 VAC 254</p>	<p>Fixed</p>
	<p>Normal - - - - -</p>	<p>220 230 VAC 240</p>	
<p>44 Slow Detect Boost High When input voltage returns below this level, PowerBack Releases the Boost mode (when enabled) and transfers back to the Line mode.</p>	<p>Boost to Line</p>	<p>216 226 VAC 236</p>	<p>Fixed</p>
<p>45 Slow Detect Boost Low When input voltage reduces below this level, PowerBack transfers to Boost Mode (only when enabled) increasing the output.</p>	<p>Line to Boost</p>	<p>210 220 VAC 230</p>	<p>Fixed</p>
<p>43 Slow Detect Low Hyst When input voltage returns above this level, PowerBack Retransfers back to the Line mode from Battery mode..</p>	<p>Battery to Boost</p>	<p>205 215 VAC 225</p>	<p>199~216 209~226 VAC 219~236</p>
<p>41 Slow Detect Low Lmt When input voltage reduces below this level, PowerBack Transfers to Battery Mode from either Boost mode (when enabled) or Line mode.</p>	<p>Boost to Battery On Battery Mode</p>	<p>199 209 VAC 219</p>	<p>193~210 203~220 VAC 213~230</p>

Figure 37

Parameter Values

2.3.5 Menu Tutorial

Purpose: shows how to use the menus (Figures 38 to 41)

This tutorial shows how to change the Battery Test Options. The other menus work the same way.

1. At the main menu (Figure 28), type 3 and press **Enter**.

The Maintenance Menu 3 appears as below (Figure 38).

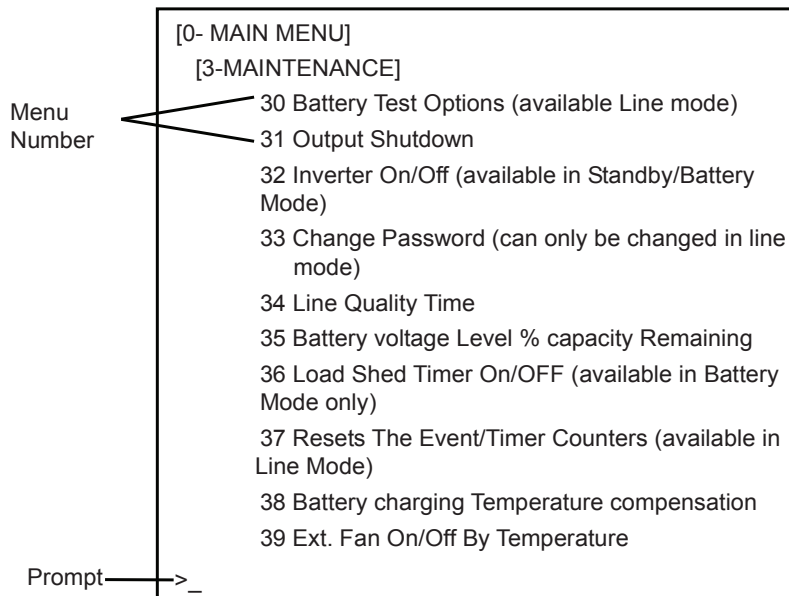
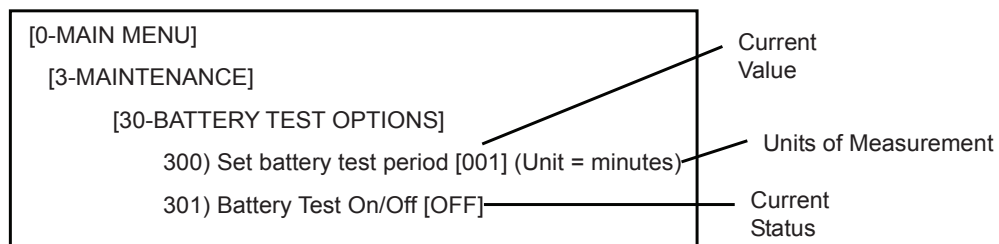

Figure 38

Maintenance Menu Screen

To the left of each maintenance option is a Menu number. Typing **30** and pressing **Enter** calls up the Battery Test Options screen (Figure 39).

2. Numbers or words inside square brackets show the present status value of that menu item.



To calculate the Test Period: Test Period = Current Value X Units

Example: Test Period = 001x 1 Minute = 1 Minute

Figure 39

Battery Test Options Screen

3. To change the battery test period, type **300** and press **Enter**.

The words “Enter password” appear on the screen. Type the password (the factory set password is 1111) and press **Enter**. If the wrong password is typed, the screen displays “Error in entering data... please try again.” Type the correct password and press **Enter**.

The Set Battery Test Period screen appears as below (Figure 40).

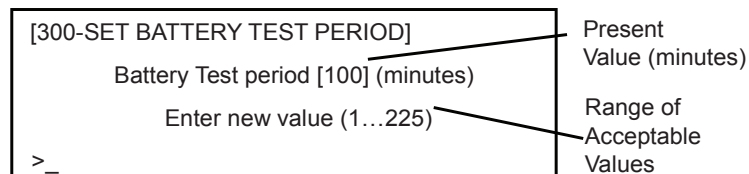

Figure 40

Set Battery Test Period Screen

Type in the new value within the acceptable range and press **Enter** to change the test period and go back to the maintenance menu screen.

4. To change the Battery Test On/Off status, type **301** and press **Enter**.

The words “ Enter password” appear on the screen. Type the password and press **Enter**.

The battery Test Screen appears (Figure 41).

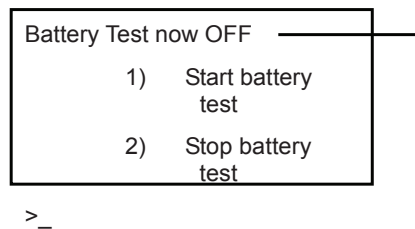

Figure 41

Battery Test Screen

Type **1** to start the battery test, or **2** to stop the battery test, and press **Enter**. This changes the battery test status and sends you back to the maintenance menu screen.

THIS PAGE INTENTIONALLY LEFT BLANK

Section 2.4

Maintenance

This section describes how to maintain the PowerBack 2000:

- 2.4.1 Battery Back-up Time Test
- 2.4.2 PowerBack Return Instructions
- 2.4.3 Troubleshooting
- 2.4.4 Specifications
- 2.4.5 Battery Maintenance

2.4.1 Battery Back-up time Test

Purpose: Describes how to measure the back up capacity of batteries.

This test provides a measurement of Back-up time during power outage by actually discharging the Batteries. The Back-up time is load dependant, hence more back-up time is available with less load (in Amps or Watts) and less time with more load.

Tip: It is recommended to perform this test every 6 months.

Tip: Make sure the batteries are fully charged before starting this test.

PROCEDURE

EXAMPLE:

Start time is **1pm**.
ON BAT contact if selected, is activated.

Low Battery Alarm LED appears at **4pm**.
LOW BAT contact at selected value will be activated.

Low Battery Capacity Battery Back-up Time will be the time difference between 4pm and 1pm or **3 hours**.

Shutdown time be **5 pm**.
Battery Reserve time will be the time difference between 4pm and 5pm or **1 hour**.

The **Total Battery Back-up** time is the sum of Low Battery Capacity back-up time and Battery Reserve Time or the time difference between 5 PM and 1 PM or 4 hours.

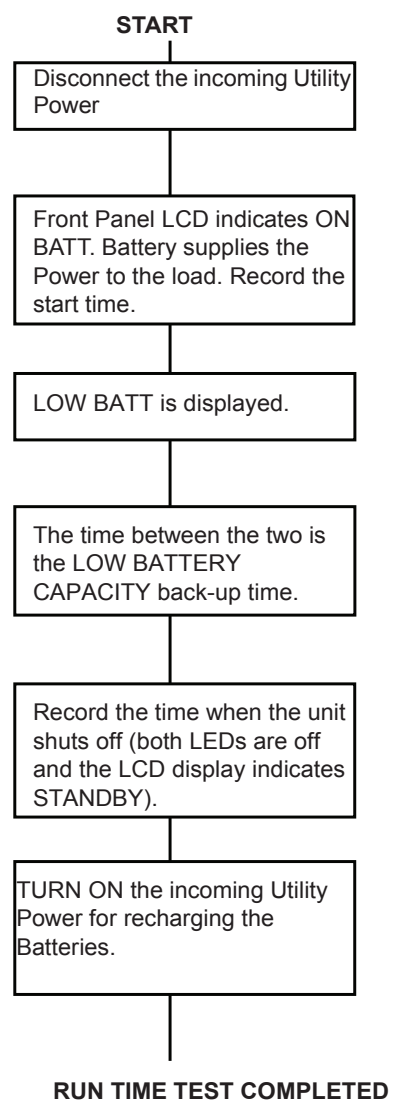

2.4.2 PowerBack Return Instructions

Purpose: Describes how to return the PowerBack 2000 for repairs.



Note: Manufacturer does not assume responsibility for damage caused by improper packaging of returned units.

Before returning a PowerBack for repair, a Return Material Authorization (RMA) number must be obtained from Customer service at following Telephone / Address. Clearly write the RMA number on the original shipping container. If you do not have the original container, pack the unit with at least three inches of shock absorbing material, but do **not** use popcorn type material. Returns should be prepaid and insured (COD and freight collect cannot be accepted).

Contact Customer Service for ordering any parts or service.

For service, parts or technical information contact:

Peek Traffic/U.S. Traffic Customer Service
2906 Corporate Way
Palmetto FL USA 34221

Phone: 1 (800) 245-7660
(941) 845-1200

Fax: (941) 845-1204

Email: tech.support@peektraffic.com

Website: www.peaktraffic.com

2.4.3 Troubleshooting

Purpose: Describes the most common problems with the PowerBack 2000.

There are NO Maintenance items inside the PowerBack. The unit should be opened or serviced only by factory authorized service personnel in order not to void the WARRANTY. If it fails to perform a specific function, Figure 42 below lists typical symptoms, causes and solutions. If you cannot resolve a problem, contact Customer Service (see 2.4.2 above).

SYMPTOM	CAUSE	REMEDY
No Output	AC Input & Output Circuit Breaker is OFF.	Turn it on.
	No incoming Utility line power.	Apply incoming Utility power by closing upstream breaker.
	Red LED is lit solid on front indicating FAULT.	Read the FAULT under Status Menu of LCD display. See 2.2.13. Clear the fault. Shut off both the breakers on the front panel. Restart. Contact the factory, if the fault still persists.
Output LED OFF	Incoming Utility power or Battery Power not available.	Apply qualified input power and verify Battery breaker to be closed.
	Faulty Unit.	Contact Factory.
Unit does not transfer to Battery mode during a power failure OR Backup time is less than rated	Battery Not Connected.	Connect Batteries (48 VDC nominal).
	Battery Circuit Breaker OFF.	Close Battery Breaker.
	Battery is not fully charged.	Fully recharge the battery then test backup time (see 2.4.1).
	Dead battery.	Replace with a good battery.
	Battery failure.	Clean and tighten battery connections. Check batteries and replace if needed.
	Faulty Unit.	Contact vendor.
Alarm LED is lit.	Red LED steady ON indicates FAULT	Correct the Fault (see 2.2.13)
	Red LED Flashing indicates ALARM.	Correct the Alarm (see 2.2.12). Contact the factory if Fault still persists.

Batteries will NOT charge.	Battery Circuit OPEN.	Check Battery connections to be properly torqued. Check Battery cable harness for connection error, Loose / Open connections. Check 46 to 56 VDC present at the Battery connector to PowerBack. Check if Battery Breaker is closed. Replace the Bad Battery, if any.
	Wrong or Bad temperature Probe connected at front panel.	Use Factory supplied temperature Probe reading approximately 12,000 OHMS. The older unit had a probe with 2,000-OHM value.
LCD screen NOT readable.	Adjust the contrast for LCD screen.	Press and HOLD ESC button. Press ENTER button. Adjust the contrast using UP or DOWN arrow buttons. Press ENTER when completed.
	Faulty Unit.	Contact Factory.
Password Access NOT available.	Entered Password is LOST or forgotten.	Call factory for resetting of the new password.

Figure 42
Troubleshooting Table

2.4.4 Contrast Adjustment for the LCD Display

1. While pushing the ESC button on the front panel,
2. Press the ENTER button and you can adjust the contrast up or down.
3. Press ENTER when adjustment is complete.

2.4.5 Battery Maintenance

The batteries are maintenance-free and their life can be affected by many factors such as: operating temperature, number of discharges during the battery's life, periodic Preventative Maintenance (see 2.4.4). This system complies with the battery manufacturer's specifications for optimum performance and the longest possible battery life.

2.4.6 Specifications

Functions	
Brownout Protection	This unit boosts the output voltage (or transfers to Battery) during Brownout or Low input line conditions and returns to Normal when input power stabilizes and returns to Normalcy. These values for Transfer / Retransfer, To / From Battery / Boost mode are user programmable.
Generator Compatibility	Generator mode allows for more variations in input voltage and frequency for use with an AC generator.
Battery Charger 10A	PFC switch-mode charger is temperature-compensated (-3 to -5 mV/C/Cell) with automatic shut off above 50 C.
Inverter Mode	Capable of running continuously in inverter mode.
Inverter Mode Current Limit	Continuous electronic current limit is provided.
Measurements available for remote monitoring	<ul style="list-style-type: none"> - Input and output voltages - Input line frequency - Battery voltage and current - Battery and heat sink temp
Mechanical Specifications	
Dimensions (H x W x D), in (mm)	5.25" x 17" x 10.5", 3U size (133 mm x 432 mm x 267 mm)
Weight, lb (kg)	46.2 (21)
Input Connection	3 Position Terminal Block
Output Connection	Two 3 Position Terminal blocks
Mounting	19" (483 mm) or 23" (584 mm) rack OR shelf mount
Cooling	Microprocessor controlled, 12V DC, 3.62" (92 mm) fan
Audible Noise Level, dBA	<40
Operating Temperature, °C	-37° to + 74°C (See Notes 1 and 2)
Storage Temperature °C	-50° to + 75°C
Humidity	Less than or equal to 95%, Non-Condensing
Altitude, ft (m)	10, 000 (3048) (See Note 2)

Electrical Specifications	
Output Apparent Power, VA	2000 (Inverter Mode) 2000 (Line Mode)
Output Active Power, W	1500 (Inverter Mode) 1500 (Line Mode)
Power Factor	0.75
Input Frequency, Hz +/- 3HZ	50/60
Input Voltage Range, VAC	193 to 262 VAC User programmable. Defaults set @ 199 ~262 VAC
Output Voltage	220/230/240 VAC Nom (Tolerances are User programmable)
Inverter Mode	220/230/240 VAC +/-5%
Maximum Input Current, A	15
Transformer	Linear (Non-Isolated)
Transfer Time, msec	<65
Inrush Current	Load Dependant
Output Waveform THD, %	< 3 (Resistive Load)
Load Crest Ratio	3:1
Efficiency, Line Mode	> 95% (Resistive Load)
Efficiency, Inverter Mode	> 80% (Resistive Load)
Nominal Battery String Voltage, VDC	48
Step Load Response (50%)	1 Cycle Full recovery.
Over current Protection	Double Pole Single Throw Circuit Breaker Rated at 15 Amp for input and output. DC Bus: 60 Amp Circuit Breaker.
Transient Suppression	MOV transient suppression elements (>150 V)
DC Power	Drawn from batteries

NOTES:

1. Between 55° and 74°C, the unit is de-rated to a maximum rectified-capacitive load of 1200W.
2. De-rate operating temperature above 4900 ft (1500m) by 5 deg. C per each additional 1000 ft (300m).

Note: Specifications subject to change without notice.

22 Position Terminal Block

Functions	<p>A. Provides 6 sets of programmable contacts at pin 1 thru pin 18 for intersection flash control, Remote Alarms, Pagers or per user's discretion.</p> <ol style="list-style-type: none"> 1. "Low Batt": the batteries reach approx 40% of capacity. 2. "On Batt": the unit is in inverter mode. 3. "Timer": the unit has been in inverter mode for 2 hours. (Timer is re-settable) 4. "Alarm": the "Alarm" contact energizes when the following conditions appear. <ol style="list-style-type: none"> a. Line Freq error b. Low O/P watt c. No Temp d. Over load e. No battery connect f. High temp g. Low Temp 5. "Fault": the "Fault" contact energizes when the following conditions appear. <ol style="list-style-type: none"> a. Short circuit b. Batt low voltage b. Batt high voltage b. High temperature e. Over load <p>A. Provides 48 VDC signal to the PTS at pin 21 & 22.</p> <p>B. Triggers the self-test by momentarily shorting pin 19 & 20 with less than 100 ohm.</p>
Contact Type	From A. Dry contacts rated to 1 Amp at 240V.
Wiring	Uses 14-26 AWG.
Communication Specifications	
RS-232 Interface	Monitors, controls and calibrates with terminal emulation software for service personnel to obtain unit diagnostics.
RS-232	DB-9, Female, Opto-Isolated
Display Panel	3 Position Terminal Block

Note: Specifications subject to change without notice.

THIS PAGE INTENTIONALLY LEFT BLANK

WARRANTY



LIMITED 24-MONTH WARRANTY

Manufacturer warrants its equipment to be free of manufacturing defects in material and workmanship for a period of 24 months from the date of manufacture. The liability of Manufacturer under this warranty is solely limited to repairing, replacing, or issuing credit for such equipment (at the discretion of Manufacturer) provided that: Manufacturer's Customer Service Department is promptly notified, by facsimile or telephone, that a failure or defect has occurred.

Manufacturer's Customer Service Department issues a Return Materials Authorization (RMA) number, and designates the service location. The RMA must be clearly marked on the outside of the shipping container.

Purchaser is responsible for all in-bound shipping and handling charges (COD and freight collect will not be accepted without prior approval from Manufacturer). Manufacturer will pay out-bound surface shipping charges for return of repaired equipment.

A satisfactory examination of the returned unit by Manufacturer's Customer Service personnel shall disclose that defects have not been caused by misuse, neglect, improper installation, repair, alteration, or accident, or failure to follow instructions furnished by Manufacturer. If Manufacturer's Customer Service personnel determine that the unit has been damaged due to one of these causes, or if the unit is free of defects, a handling or repair fee may be assessed prior to returning the unit.

BATTERIES, PERIPHERAL DEVICES, ATTACHMENTS OR APPARATUS MANUFACTURED BY THIRD PARTIES: MANUFACTURER WILL ASSIGN TO THE PURCHASER, ITS RIGHTS UNDER THE THIRD PARTY MANUFACTURER'S WARRANTY OF SUCH BATTERIES, PERIPHERAL DEVICES, ATTACHMENTS OR APPARATUS, BUT OFFERS NO ADDITIONAL WARRANTIES IN CONNECTION THEREWITH.

THIS LIMITED 24-MONTH WARRANTY IS IN LIEU OF ALL OTHER WARRANTIES, EXPRESS OR IMPLIED, INCLUDING BUT NOT LIMITED TO, IMPLIED WARRANTIES OF MERCHANT ABILITY AND FITNESS FOR A PARTICULAR PURPOSE.

IN NO CASE SHALL MANUFACTURER BE LIABLE FOR ANY INCIDENTAL, SPECIAL OR CONSEQUENTIAL DAMAGES WHATSOEVER, INCLUDING WITHOUT LIMITATION ANY CLAIM FOR LOST PROFITS OR REVENUES, EVEN IF MANUFACTURER HAS BEEN ADVISED OF THE POSSIBILITY OF SUCH, FOR BREACH OR THIS OR ANY OTHER WARRANTY, EXPRESS OR IMPLIED.

Any action for breach of this limited 24-month warranty must be brought within a period of 24 months from date of manufacture.

This limited 24-month warranty does not extend to any unit that has been repaired or altered by any party other than Manufacturer, or its Authorized Customer Service Center.

Manufacturer reserves the right to discontinue particular models and to make modifications in design and/or function at any time, without notice and without incurring obligations to modify previously purchased units.

EMERGENCY SHUTDOWN PROCEDURE

TURN-OFF BOTH THE AC & BATTERY BREAKER IN AN EMERGENCY. The PowerBack 2000 UPS contains more than one live circuit. In an emergency, AC line power may be disconnected at the system's input, but output AC power may still be present from Batteries.

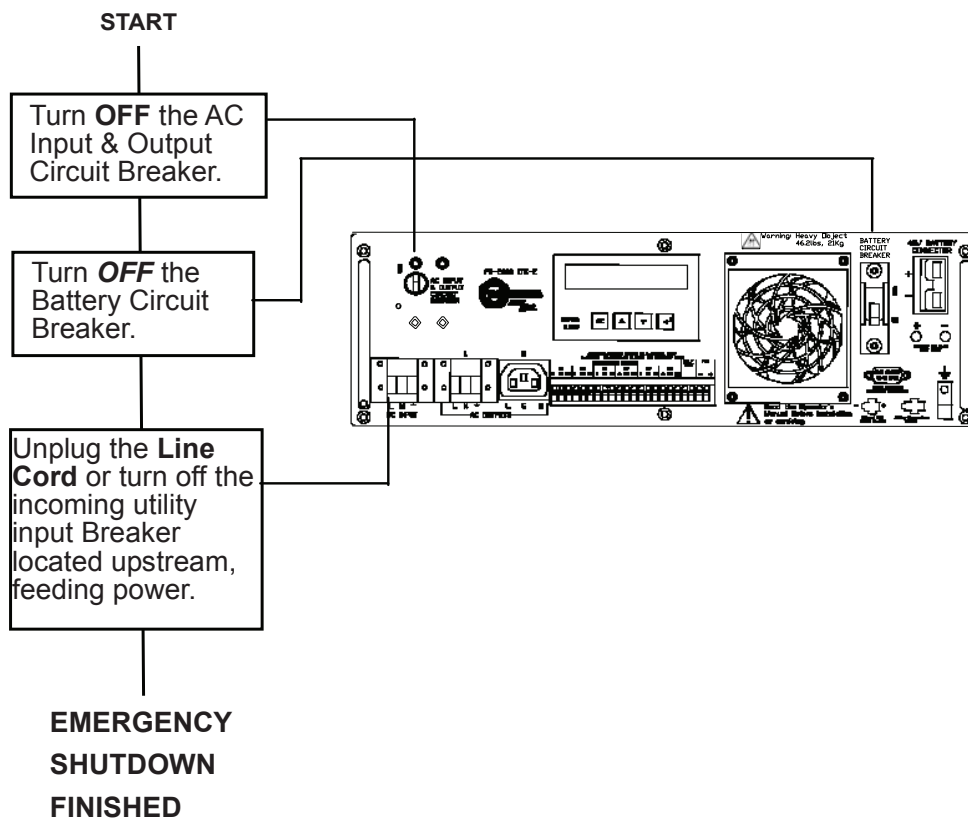

For service, parts or technical information contact:

Peek Traffic/U.S. Traffic Customer Service
2906 Corporate Way
Palmetto FL USA 34221

Phone: 1 (800) 245-7660
(941) 845-1200

Fax: (941) 845-1204

Email: tech.support@peektraffic.com
Website: www.peaktraffic.com



Peek Traffic/U.S. Traffic
2906 Corporate Way
Palmetto FL 34221 USA
(800) 245-7660
(941) 845-1200
Fax: (941) 365-0837
www.peaktraffic.com



Image



Terminal Type

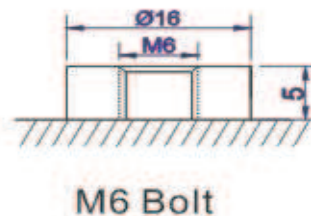

M6 Bolt

Dimensions

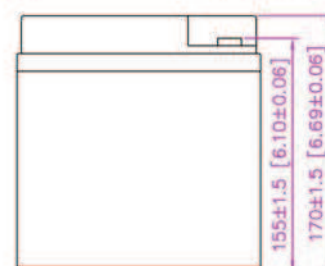
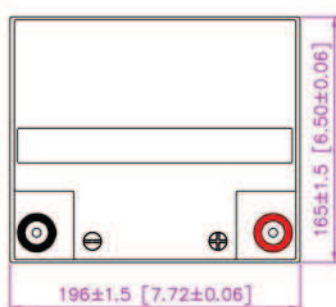
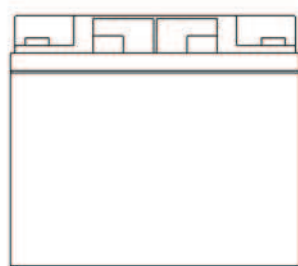

Specifications

Battery model	HC12-40			
Nominal voltage	12V			
Designed Floating Life	Up to 8-10 years			
Cycle use	1. Up to 250 cycles at 100% DOD		2. Up to 500 cycles at 50% DOD	
Capacity (25°C)	20hr (2.03A, 10.8V)	10hr (3.956A, 10.5V)	5hr (7.636A, 10.5V)	1hr (25.57A, 10.5V)
	40.60Ah	39.56Ah	38.18Ah	25.57Ah
Dimensions (approx.)	Length	Width	Height	Total Height
	196mm (7.72inch)	165mm (6.50inch)	155mm (6.106inch)	170mm (6.69inch)
Approx. Weight	12.00Kg ±5% (26.4lbs)			
Internal Resistance (approx.)	Full charged at 25°C: ≤ 10.0mΩ			
Self Discharge	2% of capacity declined per month at 25°C			
Capacity Affected by Temperature	40°C	25°C	0°C	-15°C
	102%	100%	85%	65%
Charge Voltage (25°C)	Cycle Use		Float Use	
	14.4-14.6V (-30mV/°C) , max. current: 10.00A		13.6-13.8V (-20mV/°C)	

HC series

HC Series Valve Regulated Lead Acid batteries are designed with AGM (Absorbent Glass Mat) technology, high performance plates and electrolyte to gain extra power output for common power backup system applications.

Application

Telecommunications
UPS
Control Equipment
Security system

Communication power supply
Electric Power System (EPS)
Power Plant
Medical Equipment

Cable Television
Backup power supply
DC power supply
Auto control system

Construction

Component: Raw material
Positive: Lead dioxide
Negative: Lead
Container: ABS (UL94HB) (FR-UL94V0 optional)
Cover: ABS (UL94HB) (FR-UL94V0 optional)

Sealant: Epoxy Resin
Safety Valve: EPDR (Rubber)
Terminal: Copper
Separator: Fibre Glass
Electrolyte: Sulphuric acid

*Sealed and maintenance free Non-spillable construction design Low self discharge characteristic
Unique grid alloy formula and updated manufacturing technique*



ACU ESPAÑA, S.L.
E-mail: comercial@acu.es
Web: www.heyicar.es
P.I. "Els Garrofers" - Avda. Progrés,5 – 08340 Vilassara de Mar – Barcelona - SPAIN

Tel: +34 93 754 09 60

Fax: 902 550 436

Charge Characteristic for Standby Use

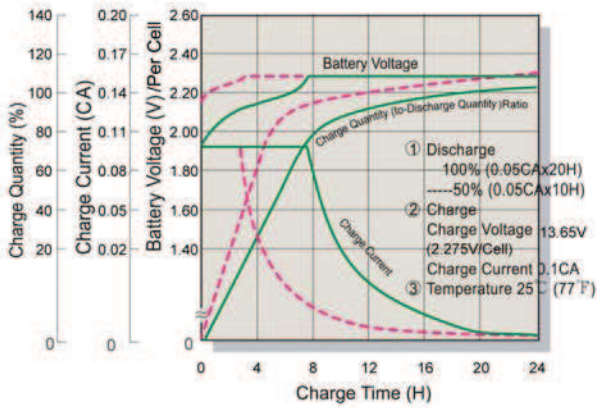

Discharge Characteristic 25°C / 20°C

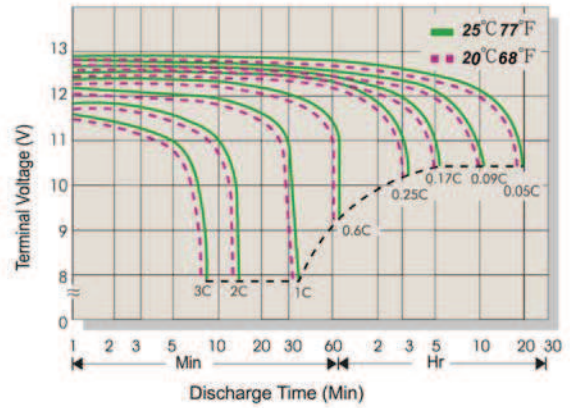

Tickle (or Float) Service Life

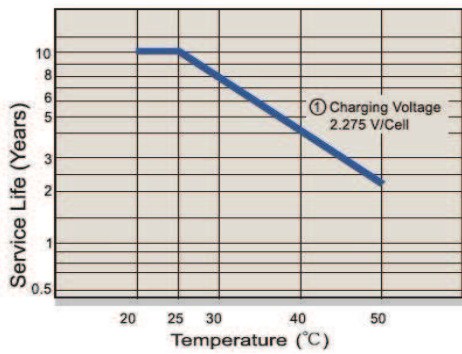

Self Discharge Characteristics

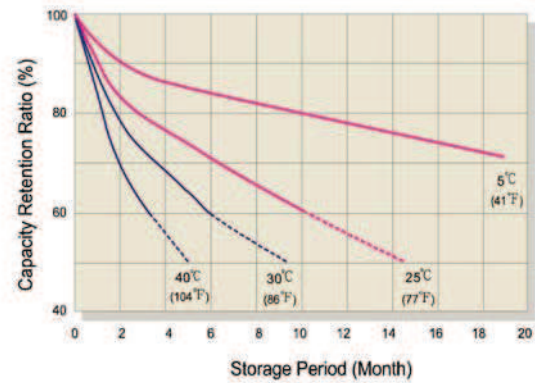

Constant Current Discharge Ratings per monoblock – Amperes at 25°C (77°F)

F.V / Time	5min	10min	15min	30min	1h	3h	5h	10h	20h
1.67V/c	173.81	98.33	77.28	48.10	26.29	10.93	7.355	4.196	2.044
1.70V/c	157.87	90.63	71.23	45.55	26.02	11.14	7.496	4.152	2.083
1.75V/c	144.84	85.50	67.20	43.80	25.57	11.35	7.636	4.080	2.122
1.80V/c	142.17	83.93	65.96	43.00	25.09	11.55	7.771	4.000	2.159
1.85V/c	139.51	82.35	64.73	42.19	24.62	11.67	7.854	3.930	2.182

Constant Current Discharge Ratings per cell – Watts/cell at 25°C (77°F)

F.V / Time	5min	10min	15min	30min	1h	3h	5h	10h	20h
1.67V/c	338.92	191.73	150.70	93.79	51.27	22.76	15.32	8.18	4.26
1.70V/c	307.86	176.73	138.90	88.83	50.73	22.52	15.15	8.10	4.21
1.75V/c	282.44	166.73	131.04	85.42	49.85	22.13	14.89	7.96	4.14
1.80V/c	277.24	163.66	128.63	83.85	48.94	21.72	14.62	7.80	4.06
1.85V/c	272.04	160.59	126.22	82.28	48.02	21.32	14.34	7.66	3.98



Ratings and features presented herein are subject to revision without notice



ACU ESPAÑA, S.L. Telf: +34 93 754 09 60 Fax: 902 550 436
 E-mail: comercial@acu.es
 Web: www.heycar.es
 P.I. "Els Garrofers" - Avda. Progrés,5 – 08340 Vilassar de Mar – Barcelona - SPAIN